

LQ104V1DW02

TFT-LCD Module

Spec. Issue Date: Aug. 26, 2005

No: LD-17817A

PREPARED BY : DATE	<h1>SHARP</h1> <p>MOBILE LIQUID CRYSTAL DISPLAY GROUP SHARP CORPORATION</p> <h2>SPECIFICATION</h2>	SPEC No. LD-17817A
APPROVED BY : DATE		FILE No.
		ISSUE : AUG. 26. 2005
		PAGE : 21 pages
		APPLICABLE GROUP MOBILE LIQUID CRYSTAL DISPLAY GROUP

REVISION: AUG. 26. 2005

DEVICE SPECIFICATION FOR

TFT-LCD Module

MODEL No.

LQ104V1DW02

These parts have corresponded with the RoHS directive.

CUSTOMER'S APPROVAL

DATE _____

BY _____

PRESENTED

BY *T. Naka*

T. NAKA
Division deputy general manager of
Mobile LCD design senter II
ENGINEERING DEPARTMENT V
MOBILE LCD DESIGN CENTER II
MOBILE LIQUID CRYSTAL DISPLAY GROUP
SHARP CORPORATION

1. Application

This specification applies to color TFT-LCD module, LQ104V1DW02

These specification sheets are the proprietary product of SHARP CORPORATION("SHARP) and include materials protected under copyright of SHARP. Do not reproduce or cause any third party to reproduce them in any form or by any means, electronic or mechanical, for any purpose, in whole or in part, without the express written permission of SHARP .

In case of using the device for applications such as control and safety equipment for transportation(aircraft, trains, automobiles, etc.), rescue and security equipment and various safety related equipment which require higher reliability and safety, take into consideration that appropriate measures such as fail-safe functions and redundant system design should be taken .

Do not use the device for equipment that requires an extreme level of reliability, such as aerospace applications, telecommunication equipment (trunk lines), nuclear power control equipment and medical or other equipment for life support.

SHARP assumes no responsibility for any damage resulting from the use of the device which does not comply with the instructions and the precautions specified in these specification sheets.

Contact and consult with a SHARP sales representative for any questions about this device.

2. Overview

This module is a color active matrix LCD module incorporating amorphous silicon TFT (Thin Film Transistor). It is composed of a color TFT-LCD panel, driver ICs, control circuit and power supply circuit and a backlight unit. Graphics and texts can be displayed on a 640 × 3 × 480 dots panel with 262,144 colors by supplying 18 bit data signal (6bit/color), four timing signals, +3.3V/ +5V DC supply voltage for TFT-LCD panel driving and supply voltage for backlight.

The TFT-LCD panel used for this module is a low-reflection, a wide-view angle, a higher-contrast and higher-color-saturation type. Therefore, this module is also suitable for the multimedia use.

Backlight-driving DC/AC inverter is not built in this module.

3. Mechanical Specifications

Parameter	Specifications	Unit
Display size	26 (10.4") Diagonal	cm
Active area	211.2(H) × 158.4(V)	mm
Pixel format	640(H) × 480(V)	pixel
	(1 pixel = R + G + B dots)	
Pixel pitch	0.330(H) × 0.330(V)	mm
Pixel configuration	R,G,B vertical stripe	
Display mode	Normally black	
Unit outline dimensions *1	246.5(W) × 179.4(H) × 15.5max(D)	mm
Mass	620(max)	g
Surface treatment	Anti-glare and hard-coating 3H	

*1: excluding backlight cables.

Outline dimensions is shown in Fig.1

Assembling form is shown in Fig.4

4. Input Terminals

4-1. TFT-LCD panel driving

CN1 Used connector: DF9MA-31P-1V(32) (Hirose Electric Co., Ltd.)

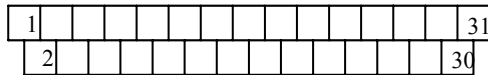

CN1 pin arrangement from module surface
(Transparent view)

Corresponding connector:

DF9-31S-1V(32) (Hirose Electric Co., Ltd.)

DF9A-31S-1V(22) (Hirose Electric Co., Ltd.)

DF9B-31S-1V(32) (Hirose Electric Co., Ltd.)

DF9C-31S-1V(22) (Hirose Electric Co., Ltd.)

() Please do not use it besides corresponding connector

Pin No.	Symbol	Function	Remark
1	GND		
2	CK	Clock signal for sampling each data signal	
3	Hsync	Horizontal synchronous signal	【Note1】
4	Vsync	Vertical synchronous signal	【Note1】
5	GND		
6	R0	R E D data signal(LSB)	
7	R1	R E D data signal	
8	R2	R E D data signal	
9	R3	R E D data signal	
10	R4	R E D data signal	
11	R5	R E D data signal(MSB)	
12	GND		
13	G0	G R E E N data signal(LSB)	
14	G1	G R E E N data signal	
15	G2	G R E E N data signal	
16	G3	G R E E N data signal	
17	G4	G R E E N data signal	
18	G5	G R E E N data signal(MSB)	
19	GND		
20	B0	B L U E data signal(LSB)	
21	B1	B L U E data signal	
22	B2	B L U E data signal	
23	B3	B L U E data signal	
24	B4	B L U E data signal	
25	B5	B L U E data signal(MSB)	
26	GND		
27	ENAB	Signal to settle the horizontal display position	【Note2】
28	Vcc	+ 3.3/5.0V power supply	
29	Vcc	+ 3.3/5.0V power supply	
30	R/L	Horizontal display mode select signal	【Note3】
31	U/D	Vertical display mode select signal	【Note4】

The shielding case is connected with GND.

【Note1】 480 line, 400 line or 350 line mode is selected by the polarity combination of the both synchronous signals.

Mode	480 lines	400 lines	350 lines
Hsync	Negative	Negative	Positive
Vsync	Negative	Positive	Negative

【Note2】 The horizontal display start timing is settled in accordance with a rising timing of ENAB signal.

In case ENAB is fixed "Low", the horizontal start timing is determined as described in 7-2.

Don't keep ENAB "High" during operation.

【Note3】 【Note4】

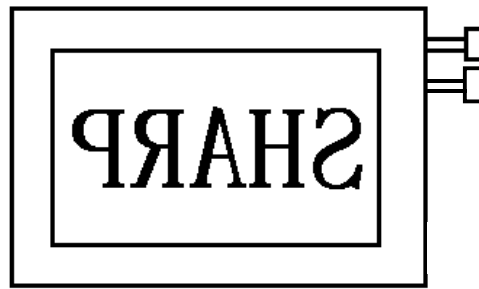
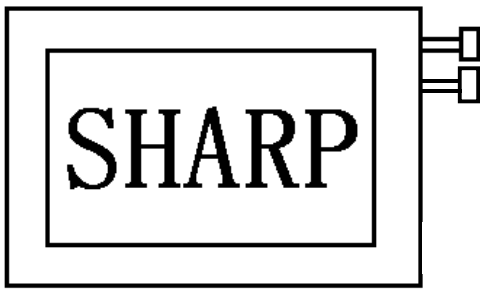

R / L = High、U / D = Low

R / L = Low、U / D = Low



R / L = High、U / D = High

R / L = Low、U / D = High

4-2. Backlight driving

Used connector : BHR-02(8.0)VS-1N (JST)
 Corresponding connector : SM02(8.0)B-BHS-1 (JST)
 SM02(8.0)B-BHS-1N (JST)

CN2, CN3

Pin no.	Symbol	Function	Cable color
1	V _{HIGH}	Power supply for lamp (High voltage side)	Pink
2	V _{LOW}	Power supply for lamp (Low voltage side)	White

【Note】 The input voltage waveform to the terminal No.1 of CN2 and CN3 should be in phase.
 There may be discharge between the terminals if it is input in opposite phase.

5. Absolute Maximum Ratings

Parameter	Symbol	Condition	Ratings	Unit	Remark
Input voltage	V _I	Ta=25	- 0.3 ~ V _{CC} + 0.3	V	【Note1】
+5V supply voltage	V _{CC}	Ta=25	0 ~ + 6	V	
Storage temperature	T _{stg}	-	- 20 ~ + 70		【Note2,3】
Operating temperature (Panel surface)	T _{opa}	-	0 ~ + 70		

【Note1】 CK,R0 ~ R5,G0 ~ G5,B0 ~ B5,Hsync,Vsync,ENAB, R/L, U/L

【Note2】 Humidity : 95%RH Max. at Ta 40 .

Maximum wet-bulb temperature at 39 or less at Ta>40 .

No condensation.

【Note3】 Maximum value : Panel surface temperature

6. Electrical Characteristics

6-1. TFT-LCD panel driving

Ta = 25

Parameter		Symbol	Min.	Typ.	Max.	Unit	Remark
Power Supply	Supply voltage	Vcc	+3.0	+3.3 +5.0	+5.5	V	【Note1】
	Current dissipation	Icc	-	185	270	mA	Vcc=3.3V 【Note2】
Icc		-	145	230	mA	Vcc=5.0V 【Note2】	
Permissible input ripple voltage		V _{RF}	-	-	100	mVp-p	
Input voltage (Low)		V _{IL}	-	-	0.3V _{cc}	V	【Note3】
Input voltage (High)		V _{IH}	0.7V _{cc}	-	-	V	
Input current 1		I _{OL1}	-10.0	-	10.0	μA	V _I =0V 【Note 4】
		I _{OH1}	-10.0	-	10.0	μA	V _I =V _{cc} 【Note 4】
Input current 2		I _{OL2}	-800	-	-	μA	V _I =0V 【Note 5】
		I _{OH2}	-10.0	-	10.0	μA	V _I =V _{cc} 【Note 5】
Input current 3		I _{OL3}	-10.0	-	10.0	μA	V _I =0V 【Note 6】
		I _{OH3}	-	-	800	μA	V _I =V _{cc} 【Note 6】

【Note 1】

Vcc-turn-on conditions

- 0 < T1 15ms
- 0 < T2 10ms
- 0 < T3 100ms
- 0 < T4 1s
- T5 > 200ms

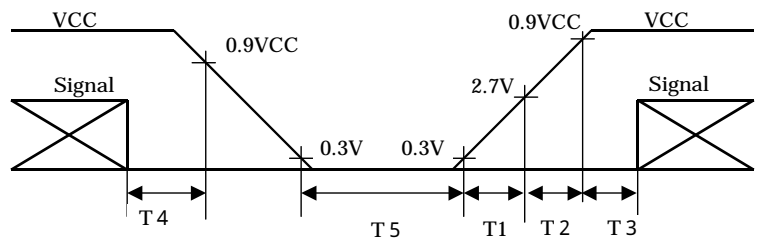

Vcc-dip conditions

- 1) 2.5V < Vcc
 - td 10ms
 - 2) Vcc < 2.5V
- Vcc-dip condition should also follow
The Vcc-turn-on conditions

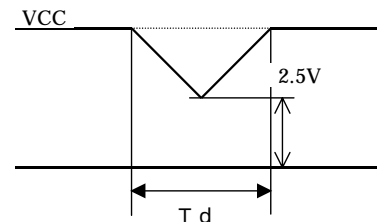

【Note2】 Typical current situation : 16-gray-bar pattern.

Vcc=+3.3V/ + 5.0V

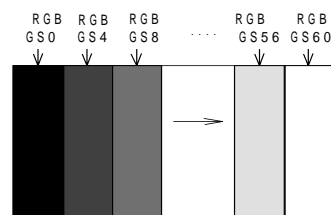

【Note3】 CK,R0~R5,G0~G5,B0~B5,Hsync,Vsync,ENAB,
R/L,U/D

【Note4】 CK,R0~R5,G0~G5,B0~B5,Hsync,Vsync,ENAB

【Note5】 R/L

【Note6】 U/D

6-2. Backlight driving

The backlight system is an edge-lighting type with double CCFT (Cold Cathode Fluorescent Tube). The characteristics of lamp are shown in the following table. (It is usually required to measure under the following condition.

condition : $I_L=6.0\text{mA}$, $T_a=25 \pm 2$, $F_L=60\text{kHz}$.)

$T_a=25$

Parameter	Symbol	Min.	Typ.	Max.	Unit	Remark
Lamp current	I_L	3.5	6.0	7.0	mArms	【Note1】
Lamp voltage	V_L	420	470	520	Vrms	
Lamp power consumption	P_L	-	2.8	-	W	【Note2】
Lamp frequency	F_L	35	60	70	KHz	【Note3】
Kick-off voltage 【Note4】	V_s	-	-	740	Vrms	$T_a=25$ 【Note8】
		-	-	(1080)	Vrms	【Note9】
		-	-	790	Vrms	$T_a=0$ 【Note8】
		-	-	(1150)	Vrms	【Note9】
Lamp life time	L_L	50000	-	-	hour	【Note5】 $I_L=6.0\text{mA}$
		30000	-	-	hour	【Note5】 $I_L=7.0\text{mA}$

【Note1】 Lamp current is measured with current meter for high frequency as shown below.

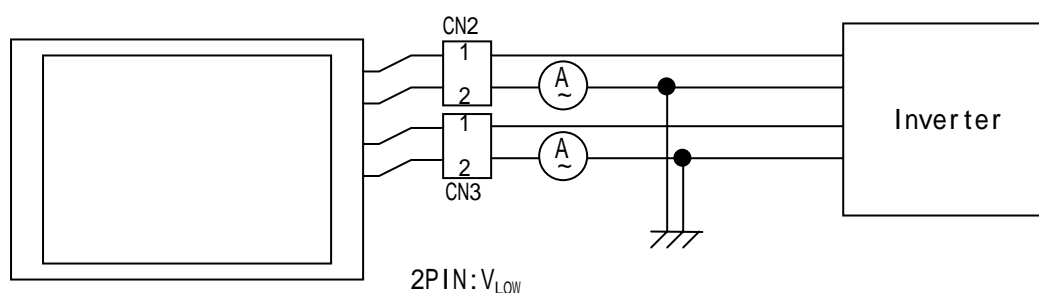

【Note2】 At the condition of $I_L=6.0\text{mArms}$

【Note3】 Lamp frequency may produce interference with horizontal synchronous frequency, and this may cause beat on the display. Therefore lamp frequency shall be detached as much as possible from the horizontal synchronous frequency and from the harmonics of horizontal synchronous to avoid interference. Please check it in a actual finished product.

【Note4】 The open output voltage of the inverter shall be maintained for more than 1sec; otherwise the lamp may not be turned on.

Please make it the circuit where the voltage does not fall till both lamps turn on.

Please connect GND of a metal case of a module and inverter circuit, the method to impress of the Voltage is Slide Up.

It is also affected by the run of connecting leads between the inverter and the backlight; therefore, when you use this for mass production, please check this by the state incorporated into the device you use and design with an allowance.

Please use the inverter of sine wave the positive wave and the negative wave of which are symmetric without occurrence of spike waves. The input voltage waveform to the terminal No.1 of CN2 and CN3 should be in phase. There may be discharge between the terminals if it is input in opposite phase.

If one of the lamps is destroyed or become unable to light for its life, voltage discharged between the terminals No.1 of CN2 and CN3 may occur, so please apply fail-safe design to an inverter circuit.

【Note5】 a) These are reference values as the lamps are consumable goods. These values are not guaranteed. Above value is applicable when lamp (the long side of LCD module) is placed horizontally. (Landscape position)

The life time is defined as the value when either of the item below is applicable when lighting continuously with $T_a=25^\circ\text{C}$ and $I_L=6.0\text{mArms}$.

(1) When the illuminance becomes 50% of the initial value.

(2) When the lighting start voltage at the lowest temperature operation becomes 810Vrms (inverter output voltage).

- b) Avoid continuous operation under low temperature as the lamp used for this module steeply decreases brightness when used under low temperature for a long time. (Continuous operation for one month under low temperature may cause decrease of the brightness to 50% of the initial value.) It is recommended to change the lamp regularly if you have to use.
Lamp lifetime may vary if lamp is in portrait position due to the change of mercury density inside the lamp.

【Note6】 The characteristics of the inverter power supply affects largely to the lighting performance and the life of the backlight. Please check to avoid lighting failure of the backlight like flicker and non-lighting by the mismatch between the backlight and the inverter power supply when you prepare the inverter power supply. It is recommended to check by the conditions as close to the actual device as possible. Please use the inverter power supply with safety circuits like over-voltage/ overcurrent detector circuits and discharge waveform detector circuits. Please use the detector circuit which can be controlled for lamp by lamp. If one side becomes open, overcurrent may flow to one lamp on the other side.

Recommended inverter is “CXA-P1212B-WJL(TDK corporation)”.

(This inverter is PWM dimmer system ($I_L=6.5\text{mA}(\text{Max})$), so it becomes $L_L=40000(\text{min})$ regardless of the dimmer.)

【Note7】 Please design considering the variation of the impedance of the two lamps and the variation of the ballast capacitor capacity of the inverter.

【Note8】 The voltage at the output of inverter circuitry

【Note9】 The voltage at the output of transformer built in inverter circuitry

Note) Insulate the high voltage area in order to prevent direct contacts to the area. As countermeasures for excessive heat or exothermic fire, use protection elements such as fuses to cut the circuit.

Use burn-resistant (or noncombustible) material for board or resin.

7. Timing Characteristics of input signals

Timing diagrams of input signal are shown in Fig.2- ~ .

7-1. Timing characteristics

Parameter		Symbol	Mode	Min.	Typ.	Max.	Unit	Remark
Clock	Frequency	1/Tc	all	-	25.18	28.33	MHz	
	High time	Tch	"	5	-	-	ns	
	Low time	Tcl	"	10	-	-	ns	
Data	Setup time	Tds	"	5	-	-	ns	
	Hold time	Tdh	"	10	-	-	ns	
Horizontal sync. signal	Cycle	TH	"	30.00	31.78	-	μs	
			"	750	800	900	clock	
	Pulse width	THp	"	2	96	200	clock	
Vertical sync. signal	Cycle	TV	480	515	525	560	line	
			400	446	449	480	line	
			350	447	449	510	line	
	Pulsewidth	TVp	all	1	-	34	line	
Horizontal display period		THd	"	640	640	640	clock	
Hsync-Clock phase difference		THc	"	10	-	Tc-10	ns	
Hsync-Vsync phase difference		TVh	"	0	-	TH-THp	clock	

Note) In case of lower frequency, the deterioration of display quality, flicker etc., may be occurred.

7-2. Horizontal display position

The horizontal display position is determined by ENAB signal and the input data corresponding to the rising edge of ENAB signal is displayed at the left end of the active area.

Parameter		symbol	Min.	Typ.	Max.	Unit	Remark
Enable signal	Setup time	Tes	5	-	Tc-10	ns	
	Pulse width	Tep	2	640	640	clock	
Hsync-Enable signal phase difference		THE	44	-	TH-664	clock	

Note) When ENAB is fixed "Low", the display starts from the data of C104(clock) as shown in Fig.2- ~ . Be careful that the module does not work when ENAB is fixed "High". When the phase difference is below 104 clock, keep the "High level of ENAB is signal longer Than 104-The. If it will not be kept, the display starts from the data of C104(clock).

7-3. Vertical display position

The vertical display position is automatically centered in the active area at each mode of VGA ,480-,400-,and 350-line mode . Each mode is selected depending on the polarity of the synchronous signals described in 4-1(Note1).

In each mode ,the data of TVn is displayed at the top line of the active area. And the display position will be centered on the screen like the following figure when the period of vertical synchronous signal,TV,is typical value.

In 400-,and 350-line mode,the data in the vertical data invalid period is also displayed, So ,inputting all data "0" is recommended during vertical data invalid period.

ENAB signal has no relation to the vertical display position.

Mode	V-data start(TVs)	V-data period(TVd)	V-display start(TVn)	V-display period	Unit	Remark
480	34	480	34	480	line	
400	34	400	443-TV	480	line	
350	61	350	445-TV	480	line	

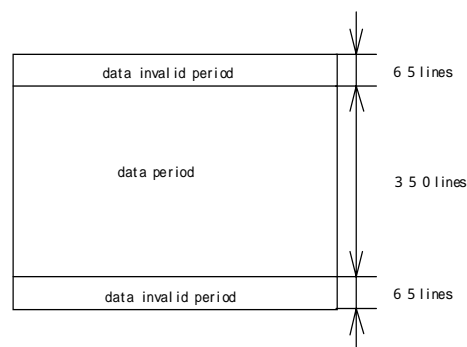
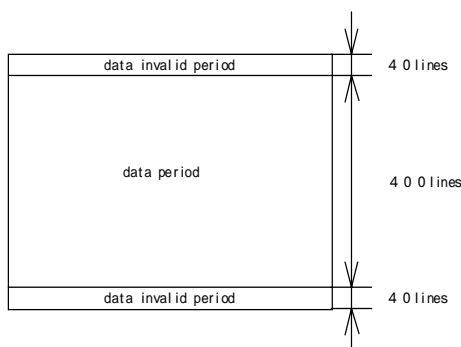

7-4. Input Data Signals and Display Position on the screen

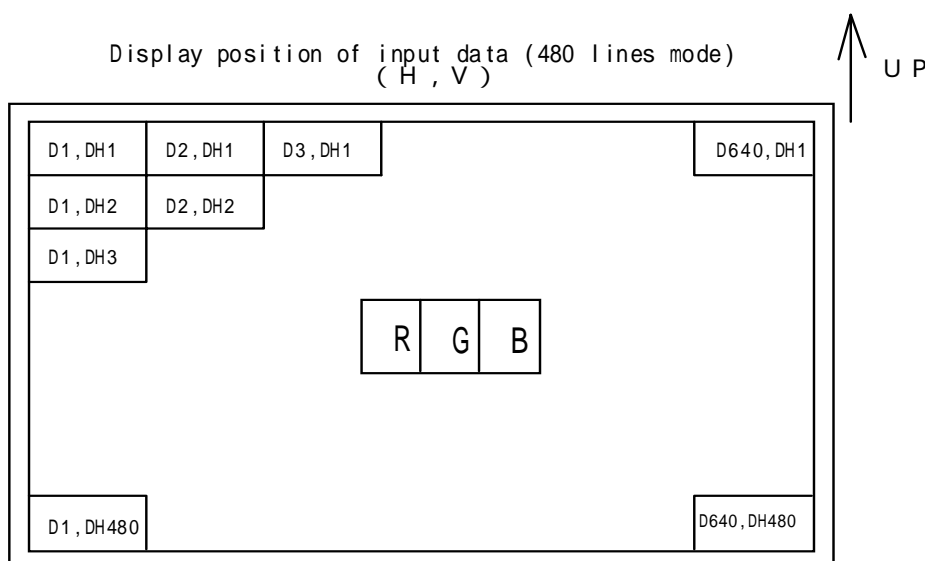

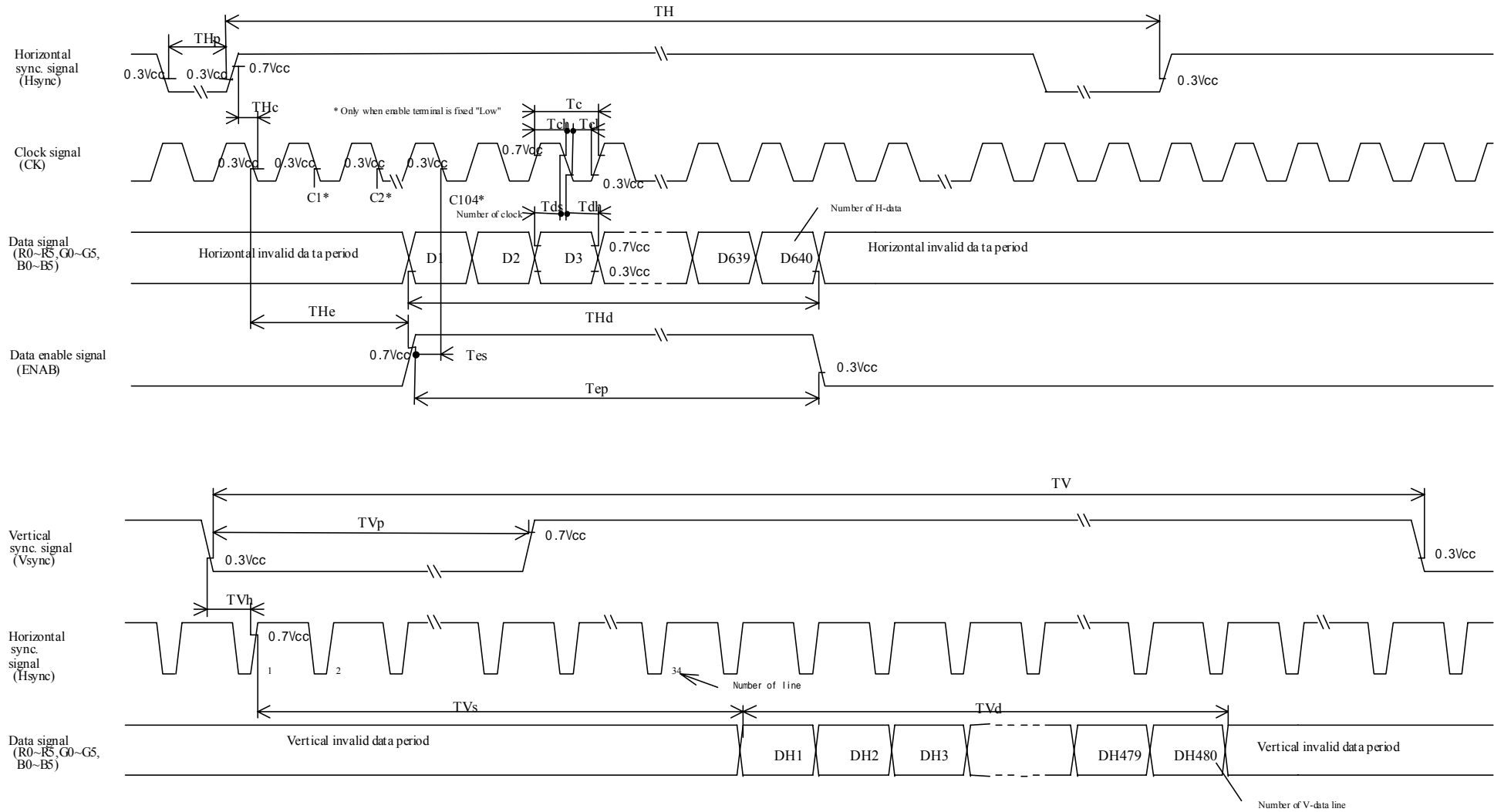

Fig2-1 Input signal waveforms (480 line mode)

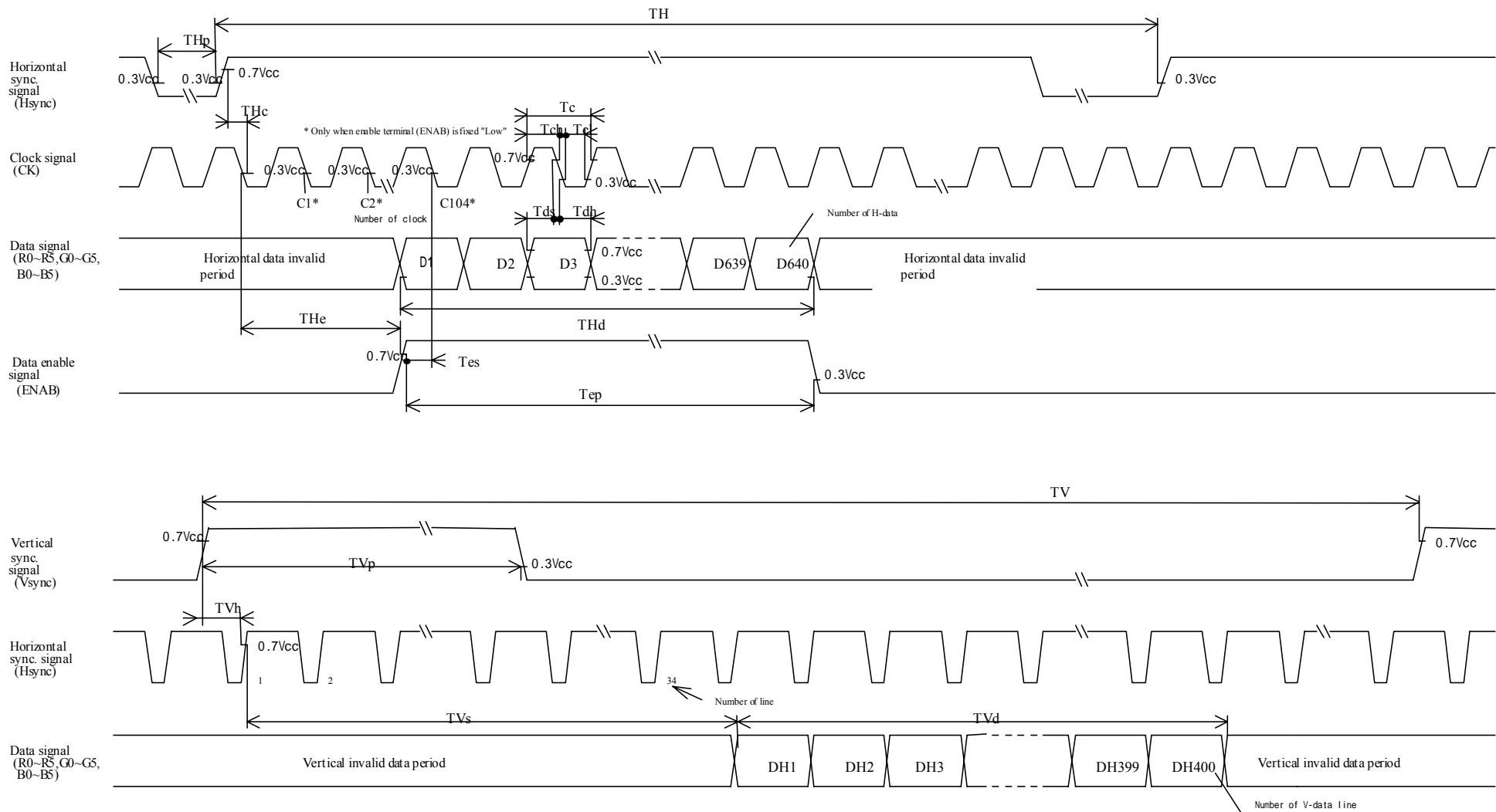

Fig.2-2 Input signal waveforms (400 line mode)

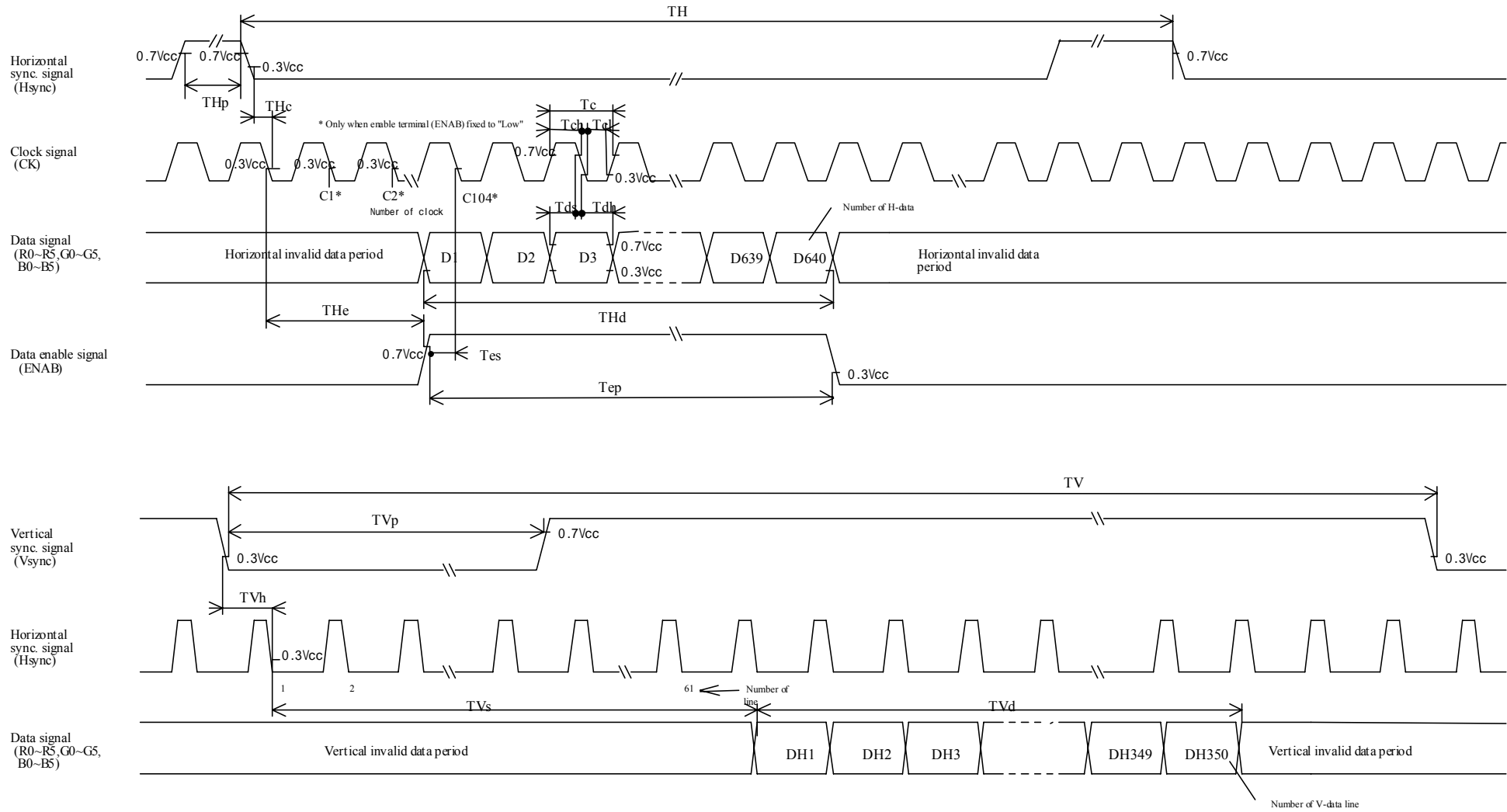

Fig.2-3 Input signal waveforms (350 line mode)

8. Input Signals, Basic Display Colors and Gray Scale of Each Color

	Colors & Gray scale	Data signal																		
		Gray Scale	R0	R1	R2	R3	R4	R5	G0	G1	G2	G3	G4	G5	B0	B1	B2	B3	B4	B5
Basic Color	Black	-	0	0	0	0	0	0	0	0	0	0	0	0	0	0	0	0	0	0
	Blue	-	0	0	0	0	0	0	0	0	0	0	0	0	1	1	1	1	1	1
	Green	-	0	0	0	0	0	0	1	1	1	1	1	1	0	0	0	0	0	0
	Cyan	-	0	0	0	0	0	0	1	1	1	1	1	1	1	1	1	1	1	1
	Red	-	1	1	1	1	1	1	0	0	0	0	0	0	0	0	0	0	0	0
	Magenta	-	1	1	1	1	1	1	0	0	0	0	0	0	1	1	1	1	1	1
	Yellow	-	1	1	1	1	1	1	1	1	1	1	1	1	0	0	0	0	0	0
	White	-	1	1	1	1	1	1	1	1	1	1	1	1	1	1	1	1	1	1
Gray Scale of Red	Black	GS0	0	0	0	0	0	0	0	0	0	0	0	0	0	0	0	0	0	0
	↑	GS1	1	0	0	0	0	0	0	0	0	0	0	0	0	0	0	0	0	0
	Darker	GS2	0	1	0	0	0	0	0	0	0	0	0	0	0	0	0	0	0	0
	↑	↓			↓					↓					↓					
	↓	↓			↓					↓					↓					
	Brighter	GS61	1	0	1	1	1	1	0	0	0	0	0	0	0	0	0	0	0	0
	↓	GS62	0	1	1	1	1	1	0	0	0	0	0	0	0	0	0	0	0	0
	Red	GS63	1	1	1	1	1	1	0	0	0	0	0	0	0	0	0	0	0	0
Gray Scale of Green	Black	GS0	0	0	0	0	0	0	0	0	0	0	0	0	0	0	0	0	0	0
	↑	GS1	0	0	0	0	0	0	1	0	0	0	0	0	0	0	0	0	0	0
	Darker	GS2	0	0	0	0	0	0	0	1	0	0	0	0	0	0	0	0	0	0
	↑	↓			↓					↓					↓					
	↓	↓			↓					↓					↓					
	Brighter	GS61	0	0	0	0	0	0	1	0	1	1	1	1	0	0	0	0	0	0
	↓	GS62	0	0	0	0	0	0	0	1	1	1	1	1	0	0	0	0	0	0
	Green	GS63	0	0	0	0	0	0	1	1	1	1	1	1	0	0	0	0	0	0
Gray Scale of Blue	Black	GS0	0	0	0	0	0	0	0	0	0	0	0	0	0	0	0	0	0	0
	↑	GS1	0	0	0	0	0	0	0	0	0	0	0	0	1	0	0	0	0	0
	Darker	GS2	0	0	0	0	0	0	0	0	0	0	0	0	0	1	0	0	0	0
	↑	↓			↓					↓					↓					
	↓	↓			↓					↓					↓					
	Brighter	GS61	0	0	0	0	0	0	0	0	0	0	0	0	1	0	1	1	1	1
	↓	GS62	0	0	0	0	0	0	0	0	0	0	0	0	0	1	1	1	1	1
	Blue	GS63	0	0	0	0	0	0	0	0	0	0	0	0	1	1	1	1	1	1

0 : Low level voltage, 1 : High level voltage

Each basic color can be displayed in 64 gray scales from 6 bit data signals. According to the combination of total 18 bit data signals, the 262,144-color display can be achieved on the screen.

9. Optical Characteristics

Ta=25 , Vcc=+5V

Parameter		Symbol	Condition	Min	Typ	Max	Unit	Remark
Viewing Angle Range	Horizontal	θ21,θ22	CR>10	70	80	-	Deg.	【Note1,4】
	Vertical	θ11,θ12		70	80	-	Deg.	
Contrast ratio		C R	θ=0°	250	450	-	-	【Note2,4】
Response Time	Rise(White→Black)	τr		-	12	-	ms	【Note3,4】
	Decay(Black→White)	τd		-	13	-	ms	
Chromaticity of White		x	0.263	0.313	0.363	-	【Note4】	
		y	0.279	0.329	0.379	-		
Luminance of white		Y L	300	380	-	cd/m ²	I _L =6.0mA _{rms} f=60kHz	

The measurement shall be executed 50 minutes after lighting at rating. (condition:I_L=6.0mA_{rms})

The optical characteristics shall be measured in a dark room or equivalent state
with the method shown in Fig below.

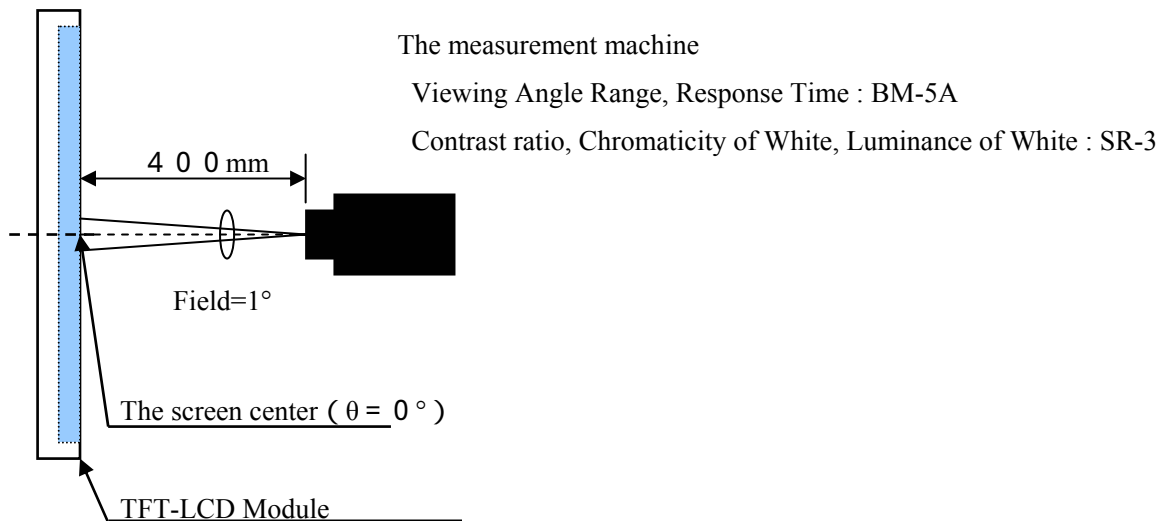

Optical characteristics measurement method.

【Note1】 Definitions of viewing angle range:

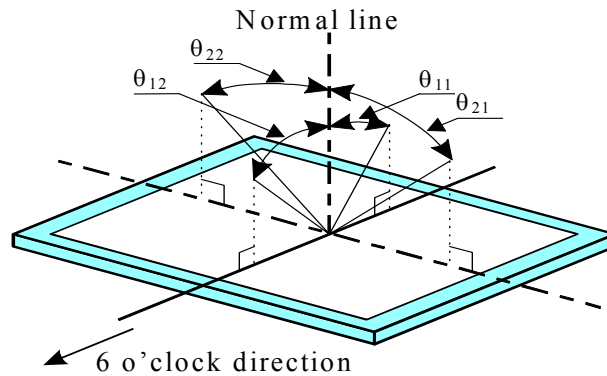

【Note2】 Definition of contrast ratio:

The contrast ratio is defined as the following.

$$\text{Contrast Ratio (CR)} = \frac{\text{Luminance (brightness) with all pixels white}}{\text{Luminance (brightness) with all pixels black}}$$

【Note3】 Definition of response time:

The response time is defined as the following figure and shall be measured by switching the input signal for "black" and "white" .

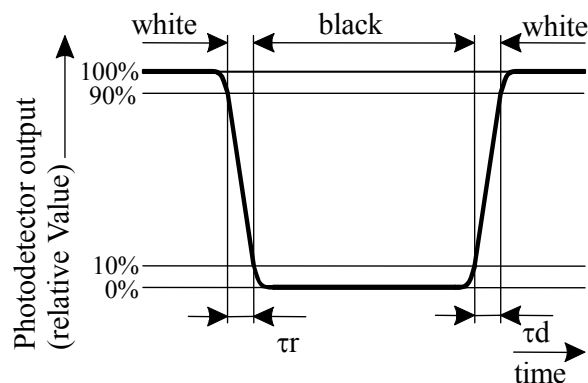

【Note4】 This shall be measured at center of the screen.

After power supply injection, measure it 50 minutes later.[An initial characteristic]

10. Display Quality

The display quality of the color TFT-LCD module shall be in compliance with the Incoming Inspection Standard.

11 . Handling Precautions

- a) Be sure to turn off the power supply when inserting or disconnecting the cable.
- b) Be sure to design the cabinet so that the module can be installed without any extra stress such as warp or twist.
- c) Since the front polarizer is easily damaged, pay attention not to scratch it.
Blow away dust on the polarizer with antistatic N₂ blow. It is undesirable to wipe off because a polarizer is sensitive. It is recommended to peel off softly using the adhesive tape when soil or finger oil is stuck to the polarizer. When unavoidable, wipe off carefully with a cloth for wiping lenses.
- d) Wipe off water drop immediately. Long contact with water may cause discoloration or spots.
- e) When the panel surface is soiled, wipe it with absorbent cotton or other soft cloth.
- f) Since the panel is made of glass, it may break or crack if dropped or bumped on hard surface.
Handle with care.
- g) Since CMOS LSI is used in this module, take care of static electricity and injure the human earth when handling. Observe all other precautionary requirements in handling electric components.
- h) Protection film is attached to the module surface to prevent it from being scratched .
Peel the film off slowly , just before the use, with strict attention to electrostatic charges.
Blow off 'dust' on the polarizer by using an ionized nitrogen.
- i) The polarizer surface on the panel is treated with Anti-Glare for low reflection. In case of attaching protective board over the LCD, be careful about the optical interface fringe etc. which degrades display quality.
- j) Do not expose the LCD panel to direct sunlight. Lightproof shade etc. should be attached when LCD panel is used under such environment.
- k) Metal cases of the module should be connected to GND. If it is not connected, items below may possibly occur.
 - a) Destabilization to EMI and external noises
 - b) Display noise that comes from the backlight
 - c) Destabilization of inverter circuit output
 - d) Partial heating
- l) There are high voltage portions on the backlight and very dangerous. Careless touch may lead to electrical shock. When exchange lamps or service, turn off the power without fail.
- m) When handling LCD modules and assembling them into cabinets, please be noted that long-term storage in the environment of oxidization or deoxidization gas and the use of such materials as reagent, solvent, adhesive, resin, etc. which generate these gasses, may cause corrosion and discoloration of the LCD modules.
- n) Cold cathode fluorescent lamp in LCD panel contains a small amount of mercury, please follow local ordinances or regulations for disposal.
- o) Please do not pull Backlight cable forcibly

- p) Liquid crystal contained inside the module coagulates under the rated storage temperature, and causes breakage of the panel. And if the temperature is beyond the rated storage temperature, liquid crystal becomes isotropic liquid and may not return to the original state. Preserve at around ambient temperature as long as possible.
- q) Because of the effect by the leakage current to the adjacent conductor caused by lamp lead run, discharge starting voltage may be required more than specified.
- r) Liquid crystal contained in the panel may leak if the LCD is broken. Rinse it as soon as possible if it gets inside your eye or mouth by mistake.
- s) The volume of the module is adjusted to the optimum when shipped, so do not modify the adjusted value. If the adjusted value is modified, it may not satisfy this spec.
- t) Notice: Never dismantle the module, because it will cause failure.
- u) Be careful when using it for long time with fixed pattern display as it may cause afterimage.
- v) Please use with off state of the TFT LCD panel drive power supply and signals, when the backlight is not lit for long time like power save mode.

Abide by the precautions which are normally applied to electronic parts.

12. Reliability test items

No.	Test item	Conditions	Remark
1	High temperature storage test	Ta=70 240h	
2	Low temperature storage test	Ta= -20 240h	
3	High temperature & high humidity operation test	Ta=40 ; 95%RH 240h (No condensation)	
4	High temperature operation test	Ta=70 (Panel surface) 240h	
5	Low temperature operation test	Ta= 0 240h	
6	ESD test	Contact charge Once for each input terminal (150pF 330) $\pm 200V$	
7	Shock test (non- operating)	Max. gravity : 490m/s ² Pulse width : 11ms, half sine wave Direction : $\pm X, \pm Y, \pm Z$ once for each direction.	
8	Vibration test (non- operating)	Frequency: 10 ~ 57Hz/Vibration width (one side):0.075mm : 57 ~ 500Hz/Gravity:9.8m/s ² Sweep time : 11 minutes Test period : 3 hours (1 hour for each direction of X,Y,Z)	

【Result Evaluation Criteria】

Under the display quality test conditions with normal operation state, these shall be no change which may affect practical display function.

13. Others

13-1 Label: Module

indication position is shown in Fig.1

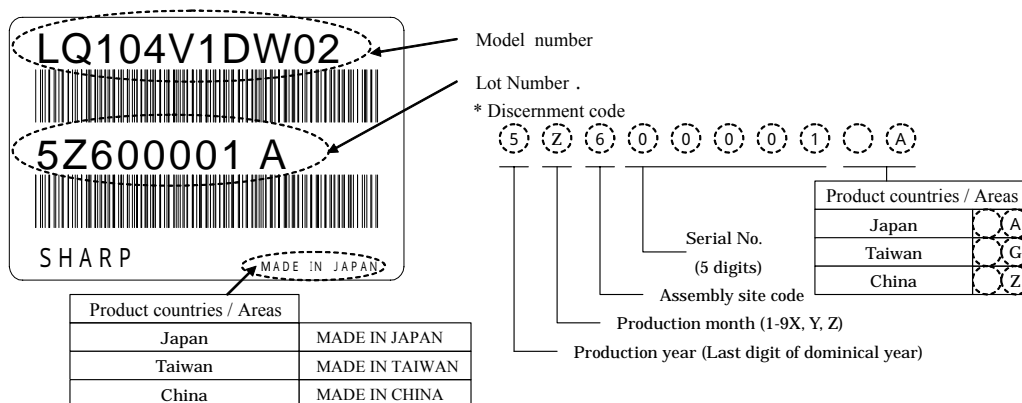

14. Packing Form

Packing form is shown in Fig3.

- Piling number of cartons: MAX. 6
- Package quantity in one carton: 10 pcs
- Carton size : 467(W)×305(D)×233(H)mm
- Total mass of 1 carton filled with full modules: 8kg
- Safekeeping condition of carton

Temperature	0 ~ 40
Humidity	Less than 60%RH
Environment	There don't be gas letting you cause corrosion
Period	Around 3 months
Environment to open	More than 60%RH
	Please carry out static electricity measures.

If any problem occurs in relation to the description of this specification , it shall be resolved through discussion with spirit of cooperation.

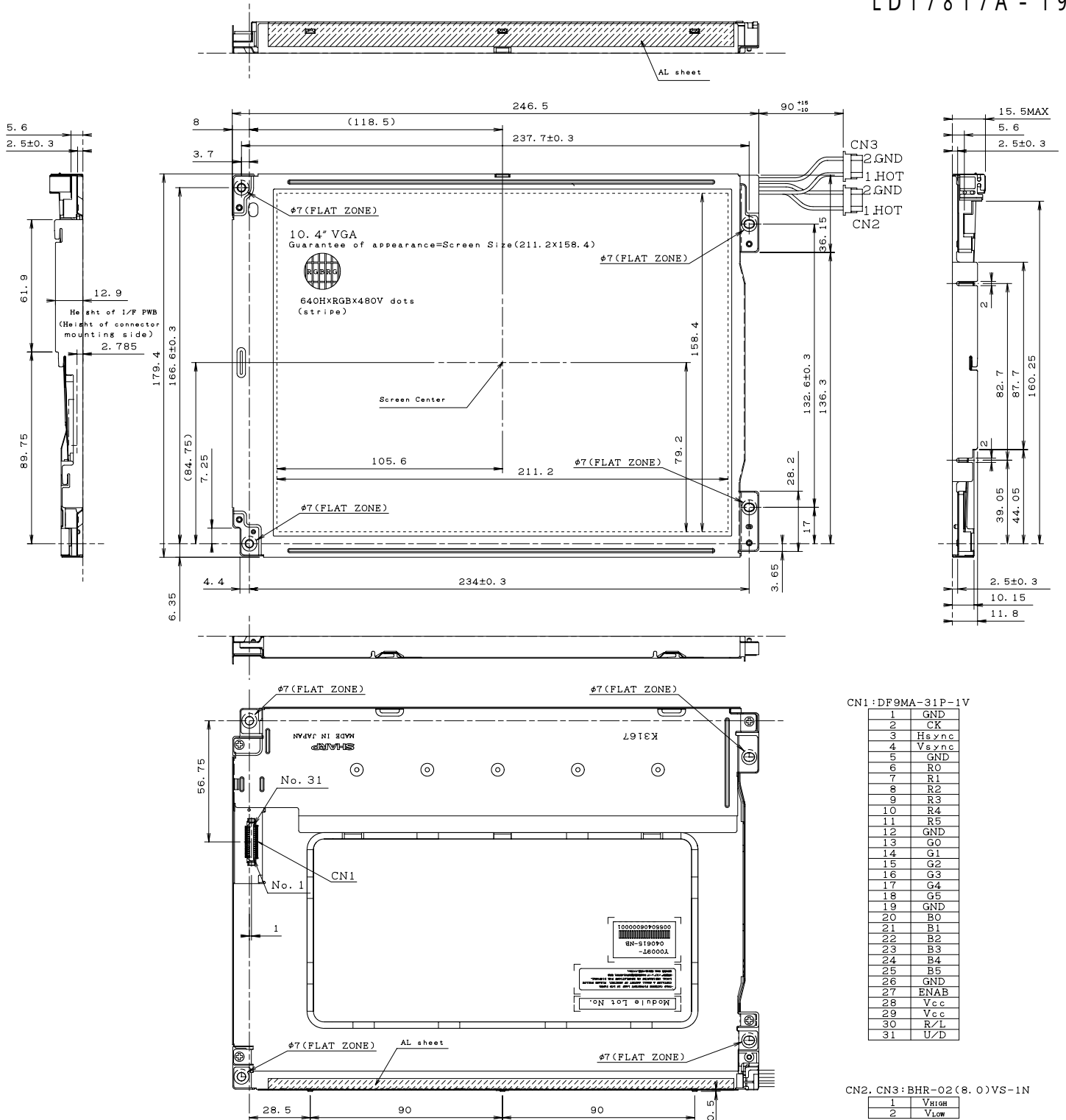

CN1:DF9MA-31P-1V

1	GND
2	CK
3	Hsync
4	Vsync
5	GND
6	R0
7	R1
8	R2
9	R3
10	R4
11	R5
12	GND
13	G0
14	G1
15	G2
16	G3
17	G4
18	G5
19	GND
20	B0
21	B1
22	B2
23	B3
24	B4
25	B5
26	GND
27	ENAB
28	Vcc
29	Vcc
30	R/L
31	U/D

CN2, CN3:BHR-02(8.0)VS-1N

1	VHIGH
2	VLOW

BEZEL/DISPLAY POSITION

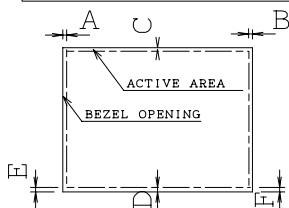

- 1) TOLERANCE X-DIRECTION A: 1.7±0.8
- 2) TOLERANCE X-DIRECTION B: 1.7±0.8
- 3) TOLERANCE Y-DIRECTION C: 2.0±0.8
- 4) TOLERANCE Y-DIRECTION D: 2.0±0.8
- 5) OBLIQUITY OF DISPLAY AREA |E-F| < 0.8

- note1) General tolerance is ±0.5
- note2) Take care of set design to hide the scratches and bubbles appeared on the polarizer or other frame area which is located outside of active area.
- note3) Wrinkle/wound/lifting/bubble of the AL sheet is not counted as a defect.
- note4) Warp and floating for printed wiring and chassis are excluded from the thickness of the unit.
- note5) Recommended tighten torque for mounting 0.294±0.02N·m(3.0±0.2kgf·cm)

Fig. 1: OUTLINE DIMENSIONS
LQ104V1DW02

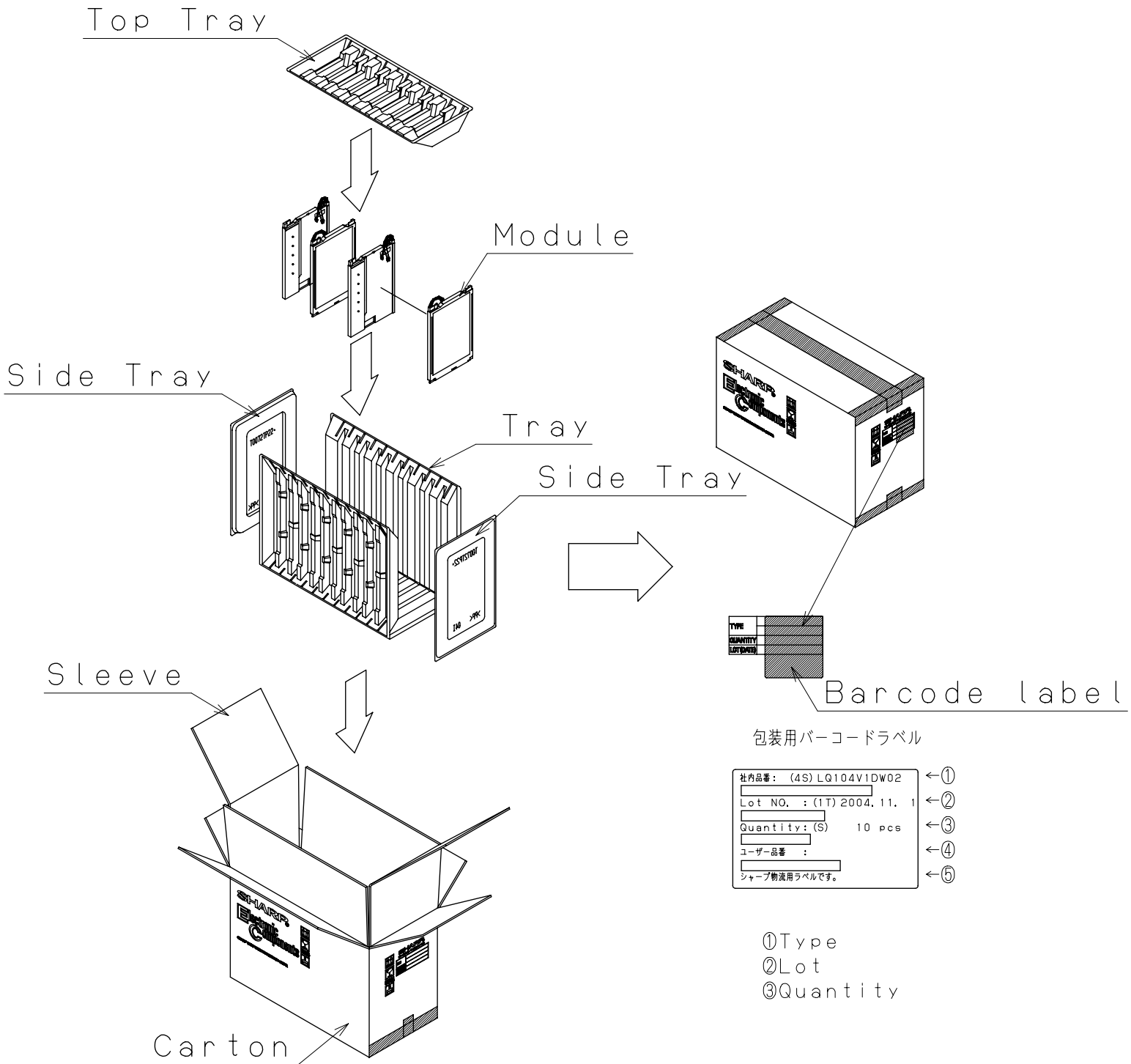

Fig. 3 Packing Form

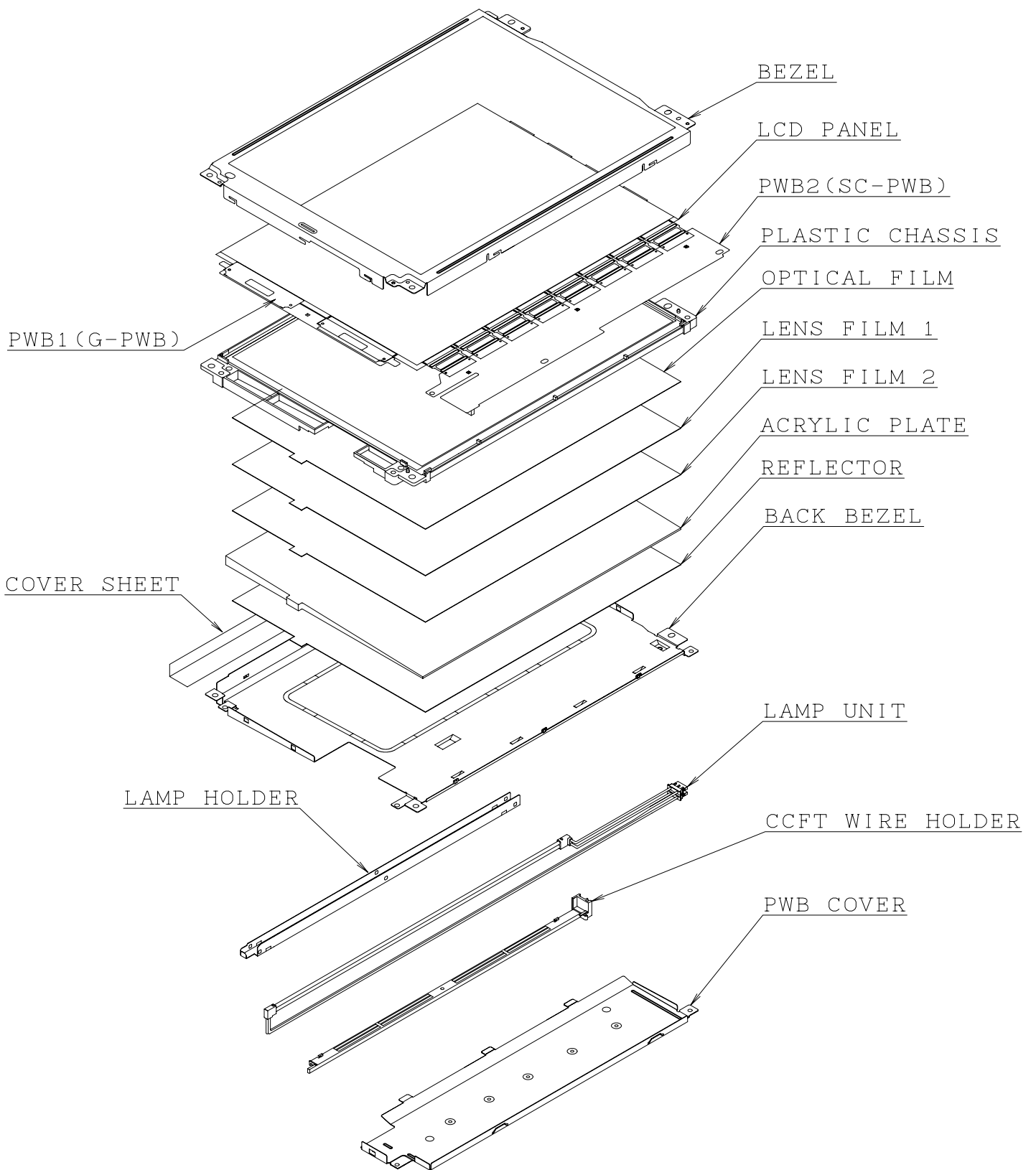

Fig4. Module Structure

SPECIFICATIONS ARE SUBJECT TO CHANGE WITHOUT NOTICE.

Suggested applications (if any) are for standard use; See Important Restrictions for limitations on special applications. See Limited Warranty for SHARP's product warranty. The Limited Warranty is in lieu, and exclusive of, all other warranties, express or implied. ALL EXPRESS AND IMPLIED WARRANTIES, INCLUDING THE WARRANTIES OF MERCHANTABILITY, FITNESS FOR USE AND FITNESS FOR A PARTICULAR PURPOSE, ARE SPECIFICALLY EXCLUDED. In no event will SHARP be liable, or in any way responsible, for any incidental or consequential economic or property damage.

SHARP®

NORTH AMERICA

SHARP Microelectronics of the Americas
5700 NW Pacific Rim Blvd.
Camas, WA 98607, U.S.A.
Phone: (1) 360-834-2500
Fax: (1) 360-834-8903
Fast Info: (1) 800-833-9437
www.sharpsma.com

EUROPE

SHARP Microelectronics Europe
Division of Sharp Electronics (Europe) GmbH
Sonninstrasse 3
20097 Hamburg, Germany
Phone: (49) 40-2376-2286
Fax: (49) 40-2376-2232
www.sharpsme.com

JAPAN

SHARP Corporation
Electronic Components & Devices
22-22 Nagaike-cho, Abeno-Ku
Osaka 545-8522, Japan
Phone: (81) 6-6621-1221
Fax: (81) 6117-725300/6117-725301
www.sharp-world.com

TAIWAN

SHARP Electronic Components
(Taiwan) Corporation
8F-A, No. 16, Sec. 4, Nanking E. Rd.
Taipei, Taiwan, Republic of China
Phone: (886) 2-2577-7341
Fax: (886) 2-2577-7326/2-2577-7328

SINGAPORE

SHARP Electronics (Singapore) PTE., Ltd.
438A, Alexandra Road, #05-01/02
Alexandra Technopark,
Singapore 119967
Phone: (65) 271-3566
Fax: (65) 271-3855

KOREA

SHARP Electronic Components
(Korea) Corporation
RM 501 Geosung B/D, 541
Dohwa-dong, Mapo-ku
Seoul 121-701, Korea
Phone: (82) 2-711-5813 ~ 8
Fax: (82) 2-711-5819

CHINA

SHARP Microelectronics of China
(Shanghai) Co., Ltd.
28 Xin Jin Qiao Road King Tower 16F
Pudong Shanghai, 201206 P.R. China
Phone: (86) 21-5854-7710/21-5834-6056
Fax: (86) 21-5854-4340/21-5834-6057

Head Office:

No. 360, Bashen Road,
Xin Development Bldg. 22
Waigaoqiao Free Trade Zone Shanghai
200131 P.R. China
Email: smc@china.global.sharp.co.jp

HONG KONG

SHARP-ROXY (Hong Kong) Ltd.
3rd Business Division,
17/F, Admiralty Centre, Tower 1
18 Harcourt Road, Hong Kong
Phone: (852) 28229311
Fax: (852) 28660779
www.sharp.com.hk

Shenzhen Representative Office:

Room 13B1, Tower C,
Electronics Science & Technology Building
Shen Nan Zhong Road
Shenzhen, P.R. China
Phone: (86) 755-3273731
Fax: (86) 755-3273735