

APREPARED BY : DATE	<h1>SHARP</h1> <p>LIQUID CRYSTAL DISPLAY GROUP SHARP CORPORATION</p> <h2>SPECIFICATION</h2>	SPEC No. LD-22906B
APPROVED BY : DATE		FILE No.
		ISSUE : Nov. 25, 2010
		PAGE : 22 pages
		APPLICABLE GROUP LIQUID CRYSTAL DISPLAY GROUP

DEVICE SPECIFICATION FOR
TFT-LCD Module
 MODEL No.
LQ121X3LG02

CUSTOMER'S APPROVAL

DATE _____

BY _____

PRESENTED

BY *K. Shiono*

K. SHIONO
 Department General Manager
 Engineering Dept. I
 LCD DIVISION III
 LIQUID CRYSTAL DISPLAY GROUP
 SHARP CORPORATION

NOTICE

This publication is the proprietary of SHARP and is copyrighted, with all rights reserved. Under the copyright laws, no part of this publication may be reproduced or transmitted in any form or by any means, electronic or mechanical for any purpose, in whole or in part, without the express written permission of SHARP. Express written permission is also required before any use of this publication may be made by a third party.

The application circuit examples in this publication are provided to explain the representative applications of SHARP's devices and are not intended to guarantee any circuit design or permit any industrial property right or other rights to be executed. SHARP takes no responsibility for any problems related to any industrial property right or a third party resulting from the use of SHARP's devices, except for those resulting directly from device manufacturing processes.

In the absence of confirmation by device specification sheets, SHARP takes no responsibility for any defects that occur in equipment using any of SHARP's devices, shown in catalogs, data books, etc. Contact SHARP in order to obtain the latest device specification sheets before using any SHARP's device.

SHARP reserves the right to make changes in the specifications, characteristics, data, materials, structures and other contents described herein at any time without notice in order to improve design or reliability. Contact SHARP in order to obtain the latest specification sheets before using any SHARP's device. Manufacturing locations are also subject to change without notice.

Observe the following points when using any device in this publication. SHARP takes no responsibility for damage caused by improper use of the devices.

The devices in this publication are designed for use in general electronic equipment designs, such as:

- Personal computers - Office automation - Telecommunication equipment
- Test and measurement equipment - Industrial control - Personal digital assistant
- Audio visual and multimedia equipment - Consumer electronics - Personal navigation device

The appropriate design measures should be taken to ensure reliability and safety when SHARP's devices are used for equipment such as:

- Transportation control and safety equipment (i.e., aircraft, trains, automobiles, etc.)
- Traffic signals - Gas leakage sensor breakers
- Alarm equipment - Various safety devices etc.

SHARP's devices shall not be used for equipment that requires extremely high level of reliability, such as:

- Military and space applications - Nuclear power control equipment
- Medical equipment for life support

Contact a SHARP representative, in advance, when intending to use SHARP's devices for any "specific" applications other than those recommended by SHARP.

Contact and consult with a SHARP representative if there are any questions about the contents of this publication.

Table of contents

1. Applicable Scope	3
2. General Description	3
3. Mechanical (Physical) Specifications	3
4. Input Terminals	4
4-1. TFT-LCD panel driving	4
4-2. LVDS interface block diagram	5
4-3. Backlight driving.....	6
5. Absolute Maximum Ratings.....	6
6. Electrical Characteristics	7
6-1. TFT LCD Panel Driving	7
6-2. Back light driving.....	9
6-3. LVDS input specification.....	10
7. Timing Characteristics of Input Signals.....	11
7-1. Timing Characteristics	11
7-2. Input data signals and display position on the screen	12
8. Input Signals, Basic Colors and Gray Scale of Each Color	13
9. Optical Characteristics.....	14
10. Display Quality.....	16
11. Handling Precautions	17
13. Reliability Test Items.....	18
14. Lot No. marking	19
14-1. Module Bar code label.....	19
14-2. Packing bar code label	19
15. RoHS.Regulations	20
16. About PFOS.....	20
17. Storage conditions	20
Fig1. LCD module packing carton	21
Fig2. 12.1XGA Outline Dimensions.....	22

1. Applicable Scope

This specification applies to a color TFT-LCD Module “LQ121X3LG02”.

2. General Description

This module is a color active matrix LCD module incorporating amorphous silicon TFT (Thin Film Transistor). It is composed of a color TFT-LCD panel, driver ICs, control circuit and power supply circuit and a back light unit.

Graphics and texts can be displayed on a 1024 x 3 x 768 dots panel with 262,144 colors by using LVDS (Low Voltage Differential Signaling) to interface and supplying +3.3V DC supply voltage for TFT-LCD panel driving and supply voltage for back light.

In this TFT-LCD panel, low reflection / color filters of excellent color performance and LED backlights of high brightness are incorporated to realize brighter and clearer pictures, making this model optimum for use in multi-media applications.

Optimum viewing direction is 6 o'clock.

LED Backlight-driving DC/DC converter is not built in this module.

3. Mechanical (Physical) Specifications

Item	Specifications	Unit
Display size	30.7 (12.1") diagonal	cm
Active area	245.8 (H) × 184.3(V)	mm
Pixel format	1024 (H) x 768 (V)	pixel
	(1Pixel = R+G+B dots)	-
Aspect ratio	4 : 3	
Pixel pitch	0.240 (H) x 0.240 (V)	mm
Pixel configuration	R,G,B vertical stripes	-
Display mode	Normally White	-
Surface treatment	Antiglare and hard-coating 2H	-

Parameter		Min.	Typ.	Max.	Unit
Unit outline dimensions	Width	258.5	259.0	259.5	mm
	Height	204.5	205.0	205.5	mm
	Depth	—	7.5	8.0	mm
Mass [Note 3-1]		—	530	550	g

Outline dimensions is shown in Fig.2

[Note 3-1] excluding LED backlight FPC and the mounting tab.

4. Input Terminals

4-1. TFT-LCD panel driving

CN1 (LVDS signals and +3.3V DC power supply)

Pin No.	Symbol	Function	Remark
1	Vcc	+3.3V power supply	
2	Vcc	+3.3V power supply	
3	GND		
4	GND		
5	RxIN0-	Receiver signal of LVDS CH0 (-)	[Note 4-1]
6	RxIN0+	Receiver signal of LVDS CH0 (+)	[Note 4-1]
7	GND		
8	RxIN1-	Receiver signal of LVDS CH1 (-)	[Note 4-1]
9	RxIN1+	Receiver signal of LVDS CH1 (+)	[Note 4-1]
10	GND		
11	RxIN2-	Receiver signal of LVDS CH2 (-)	[Note 4-1]
12	RxIN2+	Receiver signal of LVDS CH2 (+)	[Note 4-1]
13	GND		
14	CK IN-	Receiver signal of LVDS CLK (-)	[Note 4-1]
15	CK IN+	Receiver signal of LVDS CLK (+)	[Note 4-1]
16	GND		
17	NC		[Note 4-2]
18	NC		[Note 4-2]
19	GND		
20	GND		

[Note 4-1] Relation between RxINi(i=0,1,2) and actual data is shown in following section (4-2)(7-2).

[Note 4-2] Please use NC by OPEN or GND. NC terminal is not connected with the internal circuit.

Using connector : DF19L-20P-1H (HIROSE) or equivalent.

Corresponding connector : DF19G-20S-1C(HIROSE)

(Sharp is not responsible to its product quality, if the user applies a connector not corresponding to the above model.)

4-2. LVDS interface block diagram

Using receiver : Single LVDS interface contained in a control IC

Corresponding Transmitter : THC63LVDM63A (THINE) or equivalent

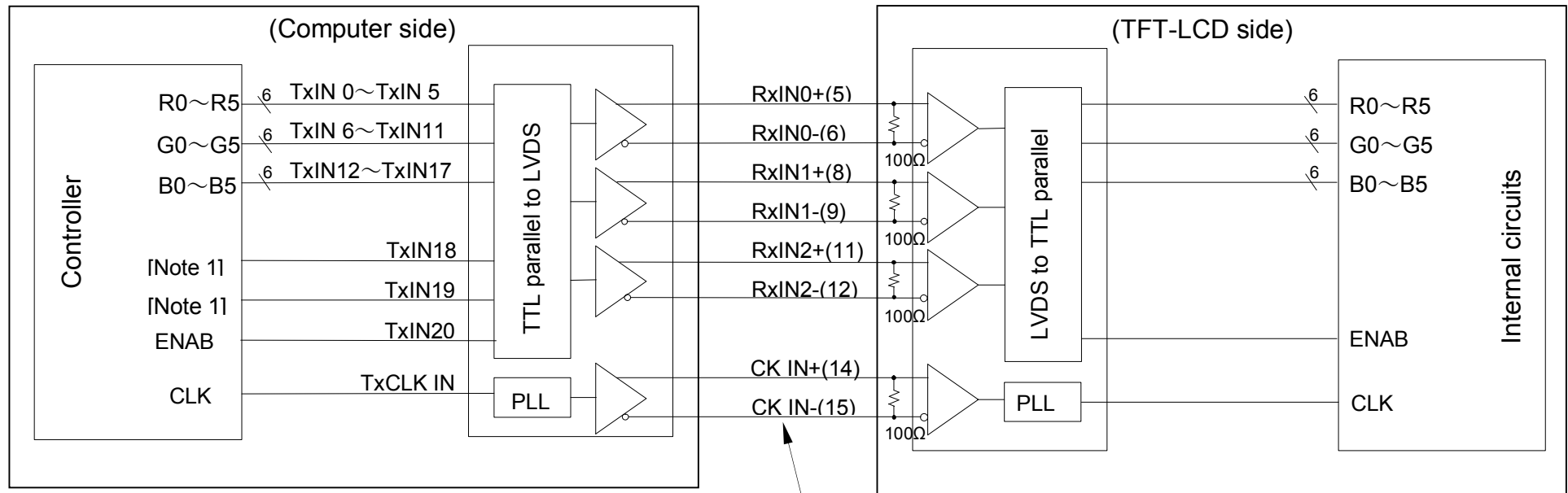

[Note] Do not use at high-impedance TxIN 18 - 19.

Symbol of CN1 (Pin No.)

4-3. Backlight driving

LED-Back Light FPC

Pin No.	Symbol	Function	Remark
1	LED_C1	LED-B/L Cathode1	
2	LED_C2	LED-B/L Cathode2	
3	LED_C3	LED-B/L Cathode3	
4	LED_C4	LED-B/L Cathode4	
5	LED_C5	LED-B/L Cathode5	
6	NC		[Note 4-3]
7	LED_A	LED-B/L Anode	
8	LED_A	LED-B/L Anode	
9	LED_A	LED-B/L Anode	
10	LED_A	LED-B/L Anode	

[Note 4-3] Please use NC by OPEN. NC terminal is not connected with the internal circuit.

Corresponding connector : 52746-1071(MOLEX)

(Sharp is not responsible to its product quality, if the user applies a connector not corresponding to the above model.)

5. Absolute Maximum Ratings

Item	Symbol	Conditions	Rated value		Unit	Remarks
			Min.	Max.		
Input voltage	V_I	$T_a = 25^\circ\text{C}$	-0.3	$V_{CC}+0.3$	V	[Note 5-1]
+3.3V supply voltage	V_{CC}	$T_a = 25^\circ\text{C}$	0	+4.0	V	
LED forward current	I_{LED_F}	$T_a = 25^\circ\text{C}$	0	280	mA	[Note 5-2]
LED reverse current	I_{LED_R}	$T_a = 25^\circ\text{C}$	—	85	mA	
Storage Temperature	T_{stg}	-	-35	+75	$^\circ\text{C}$	[Note 5-3]
Operating Temperature (Ambient)	T_{opr}	$T_a = 25^\circ\text{C}$	-20	+50	$^\circ\text{C}$	[Note 5-3,5-4]

[Note 5-1] LVDS signals

[Note 5-2] Value for one LED string

[Note 5-3] Humidity : 90%RH Max. at $T_a \leq +40^\circ\text{C}$.

Maximum wet-bulb temperature at $+39^\circ\text{C}$ or less at $T_a > +40^\circ\text{C}$.

No condensation.

[Note 5-4] Temperature of Panel surface is 60°C Max.

6. Electrical Characteristics

6-1. TFT LCD Panel Driving

Ta = 25°C

Parameter	Symbol	Min.	Typ.	Max.	Unit	Remark
Supply voltage	V_{CC}	+3.0	+3.3	+3.6	V	[Note 6-2]
Current dissipation	I_{CC}	—	380	600	mA	[Note 6-3]
Permissible input ripple voltage	V_{RP}	—	—	100	mV _{P-P}	$V_{CC} = +3.3V$
Input voltage range	V_I	0	—	2.4	V	LVDS signals
Differential input threshold voltage	High	V_{TH}	—	+100	mV	$V_{CM} = +1.2V$ [Note 6-1]
	Low	V_{TL}	-100	—	mV	
Input current (High)	I_{OH}	—	—	±10	μA	$V_I = +2.4V$ $V_{CC} = +3.6V$
Input current (Low)	I_{OL}	—	—	±10	μA	$V_I = 0V$ $V_{CC} = 3.6V$
Terminal resistor	R_T	—	100	—	Ω	Differential input

[Note 6-1] V_{CM} : Common mode voltage of LVDS driver.

[Note 6-2] On-off conditions for supply voltage

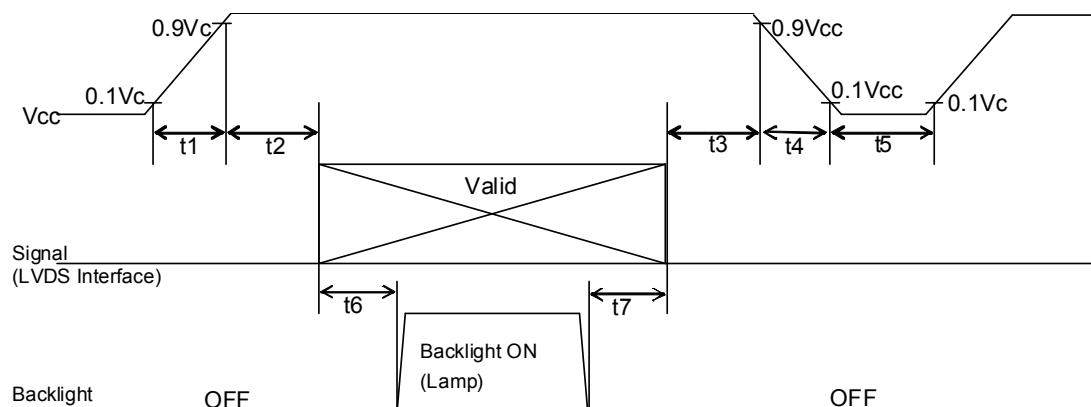

Symbol	Min.	Max.	Unit	Remark
t1	0	10	ms	
t2	0	1	s	
t3	0	1	s	
t4	0	400	ms	
t5	200	—	ms	
t6	180	—	ms	*1
t7	5	—	ms	*1

*1 : As for the power sequence for backlight, it is recommended to apply above mentioned input timing. If the backlight is lit on and off at a timing other than shown above, displaying image may get disturbed. This is due to variation of output signal from timing generator when LVDS signal is changed from on to off or vice versa, but has no harm to the module itself.

【Note】 Do not keep the interface signal high-impedance or unusual signal when power is on.

Vcc-dip conditions

1) $2.5\text{ V} \leq V_{cc} < 3.0\text{ V}$

$T_d \leq 10\text{ ms}$

Under above condition, the display image should return to an appropriate figure after Vcc voltage recovers.

2) $V_{cc} < 2.5\text{ V}$

Vcc-dip conditions should also follow the On-off conditions for supply voltage

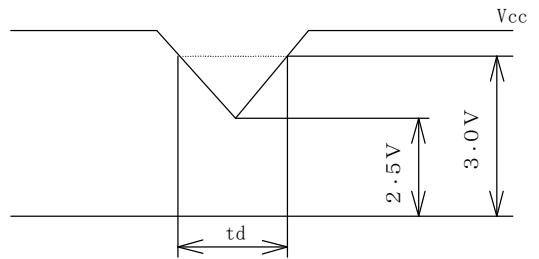

[Note 6-3] Typical current situation : 16-gray-bar pattern.

$V_{cc} = +3.3\text{V}$

Maximum current situation : $V_{cc} = +3.0\text{V}$

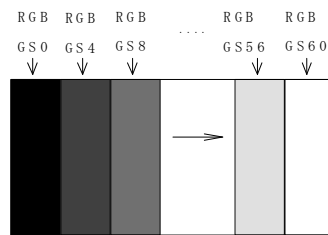

6-2. Back light driving

The backlight system is edge-lighting type with 40 White-LED(White Light Emitting Diode).

The characteristics of White-LED are shown in the following table.

(Ta=25 °C)

Parameter	Symbol	Min.	Typ.	Max.	Unit	Remark
LED forward voltage	V_{LED_F}	—	24.0	27.2	V	[Note 6-4]
LED forward voltage variation	ΔV_{LED_F}	—	—	3.2	V	[Note 6-4, 6-5]
LED forward current range	I_{LED_F}	—	70	70	mA	Value for one string
Number of circuit strings		—	5	—		[Note 6-6]
LED power consumption	W_{LED}	—	8.4	9.5	W	[Note 6-4, 6-7]
LED life time	L_{LED}	50000	—	—	Hour	[Note 6-8]

[Note 6-4] $I_{LED_F} = 70\text{mA}$

[Note 6-5] Variation of V_{LED_F} between each string in one LCD module.

[Note 6-6] The LED backlight is composed by 5 strings from which 8 LED is connected with the series.

The figure below shows the circuit chart of each string.

In each circuit, there is a ceramic capacitor for the electrostatic protection.

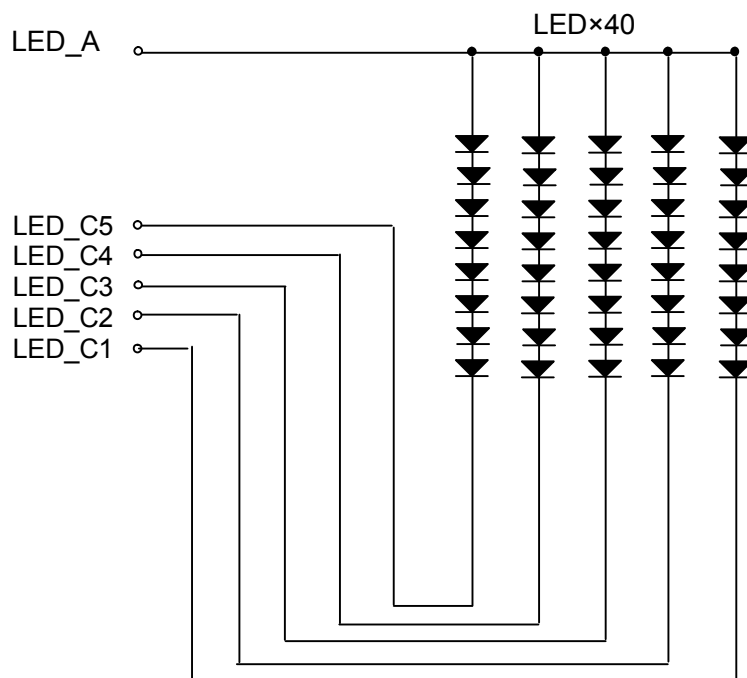

[Note 6-7] Calculated value for reference ($I_{LED_F} \times V_{LED_F}$)

[Note 6-8] LED life time is defined as the time when Brightness becomes 50 % of the original value. under the condition of Ta = 25 °C and $I_{LED_F} = 70\text{mA}$, and continuous lighting.

6-3. LVDS input specification

6-3-1. AC characteristics

V_{CC}=+3.0V~+3.6V, T_a=-20°C~+60°C

Parameter	Symbol	Min	Typ.	Max.	Unit
Input Data Position 0 (t _{RCIP} =15.38ns)	t _{RIP1}	-0.25	0.0	+0.25	ns
Input Data Position 1 (t _{RCIP} =15.38ns)	t _{RIP0}	t _{RCIP} /7-0.25	t _{RCIP} /7	t _{RCIP} /7+0.25	ns
Input Data Position 2 (t _{RCIP} =15.38ns)	t _{RIP6}	2 t _{RCIP} /7-0.25	2 t _{RCIP} /7	2 t _{RCIP} /7+0.25	ns
Input Data Position 3 (t _{RCIP} =15.38ns)	t _{RIP5}	3 t _{RCIP} /7-0.25	3 t _{RCIP} /7	3 t _{RCIP} /7+0.25	ns
Input Data Position 4 (t _{RCIP} =15.38ns)	t _{RIP4}	4 t _{RCIP} /7-0.25	4 t _{RCIP} /7	4 t _{RCIP} /7+0.25	ns
Input Data Position 5 (t _{RCIP} =15.38ns)	t _{RIP3}	5 t _{RCIP} /7-0.25	5 t _{RCIP} /7	5 t _{RCIP} /7+0.25	ns
Input Data Position 6 (t _{RCIP} =15.38ns)	t _{RIP2}	6 t _{RCIP} /7-0.25	6 t _{RCIP} /7	6 t _{RCIP} /7+0.25	ns
Phase Lock Loop Set	t _{RPLL}	—	—	10	ms
Input Clock Period	t _{RCIP}	14.9	15.4	20	ns

LVDS input timing

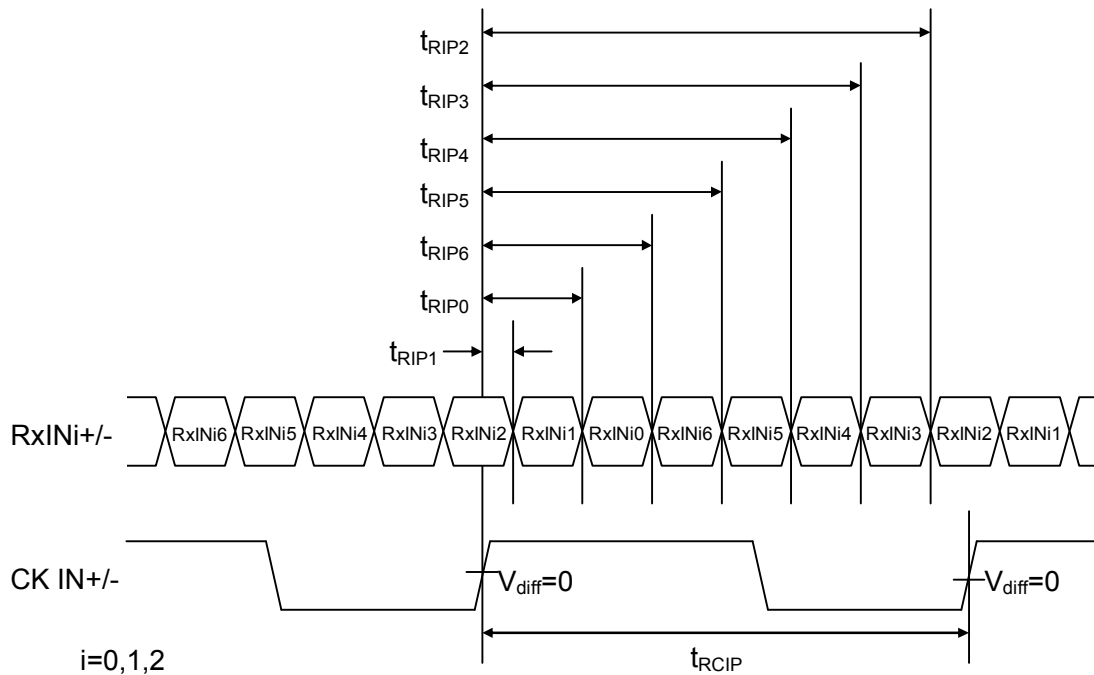

※Note

V_{diff}=(RxINi+)-(RxINi-), (CK IN+)-(CK IN-)

LVDS phase lock loop set

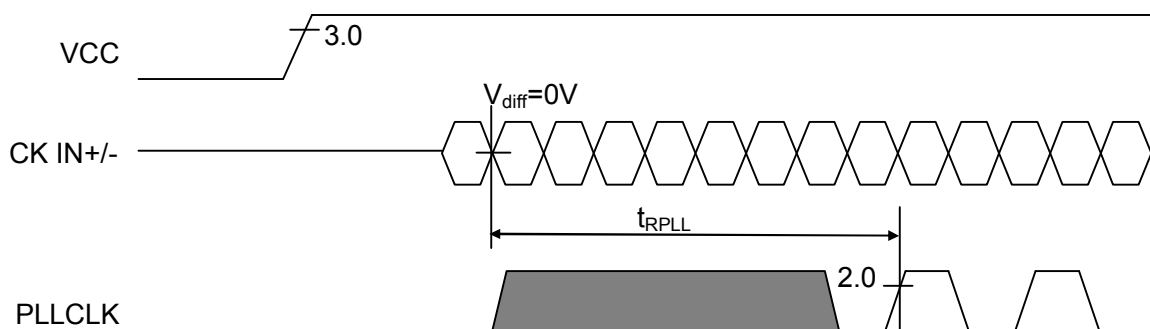

6-3-2. LVDS data

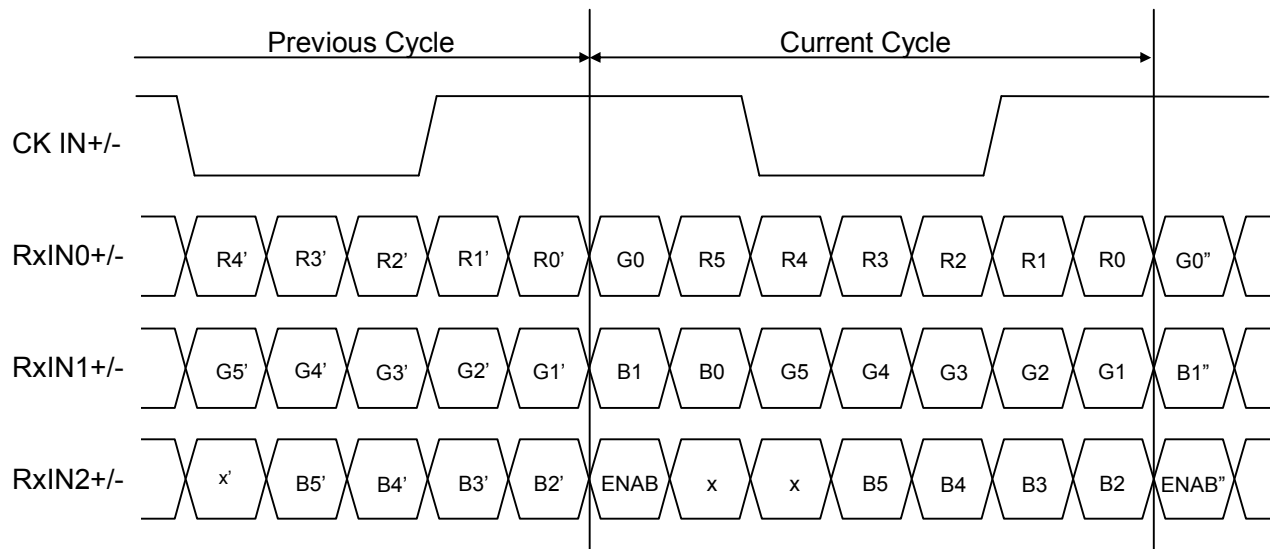

7. Timing Characteristics of Input Signals

7-1. Timing Characteristics

(It provides by outputting the digital signal of LVDS-IC)

$V_{CC}=+3.0V\sim+3.6V$, $T_a=-20^{\circ}C\sim+60^{\circ}C$

Parameter		Symbol	Min.	Typ.	Max.	Unit	Remark
Clock	Frequency	1/Tc	50	65	67	MHz	[Note 7-1]
Data enable Signal	Horizontal period	TH	1260	1344	1408	clock	
			19.38	20.68	—	μs	
	Horizontal period (High)	THd	1024	1024	1024	clock	
	Vertical period	TV	803	806	900	Line	
			15.56	16.67	—	ms	
Vertical period (High)	TVd	768	768	768	line		

[Note 7-1] In case of using the long vertical period, the deterioration of display quality, flicker, etc, may occur.

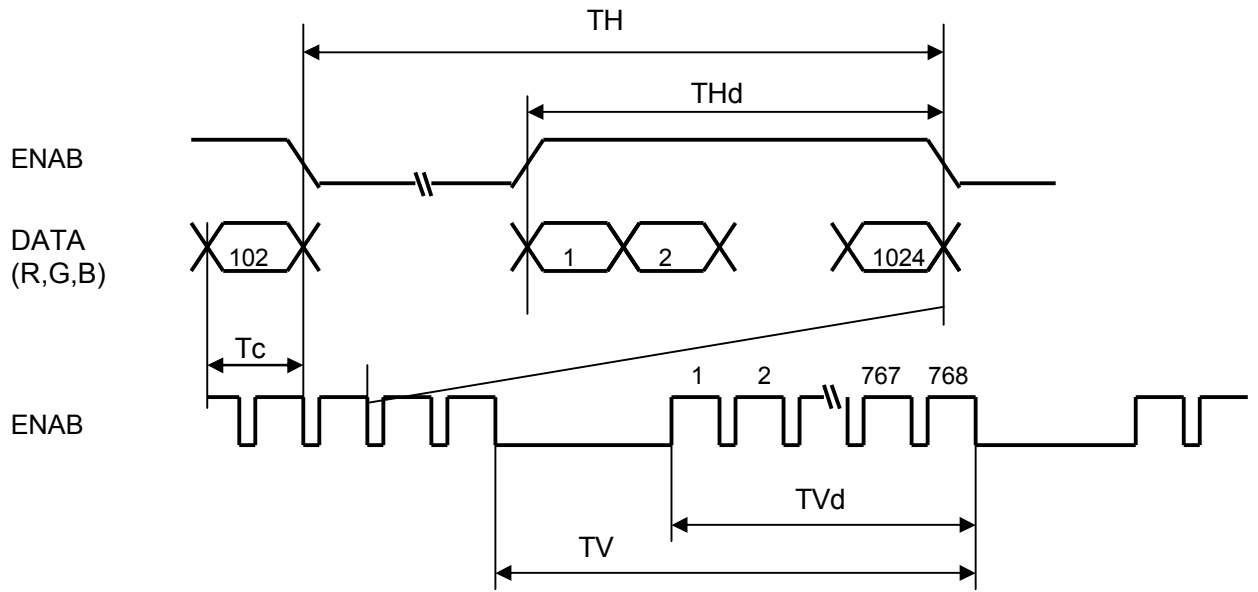

7-2. Input data signals and display position on the screen

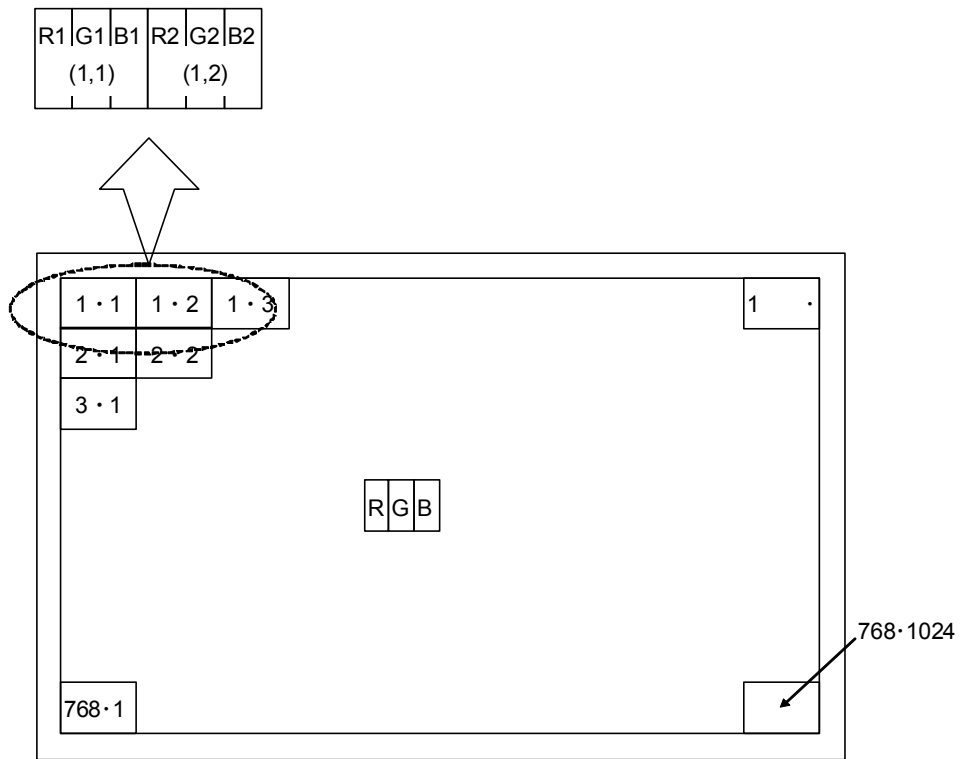

Display position of input data(V · H)

8. Input Signals, Basic Colors and Gray Scale of Each Color

	Colors & Gray scale	Data signal																		
		Gray Scale	R0	R1	R2	R3	R4	R5	G0	G1	G2	G3	G4	G5	B0	B1	B2	B3	B4	B5
Basic Color	Black	—	0	0	0	0	0	0	0	0	0	0	0	0	0	0	0	0	0	0
	Blue	—	0	0	0	0	0	0	0	0	0	0	0	0	1	1	1	1	1	1
	Green	—	0	0	0	0	0	0	1	1	1	1	1	1	0	0	0	0	0	0
	Cyan	—	0	0	0	0	0	0	1	1	1	1	1	1	1	1	1	1	1	1
	Red	—	1	1	1	1	1	1	0	0	0	0	0	0	0	0	0	0	0	0
	Magenta	—	1	1	1	1	1	1	0	0	0	0	0	0	1	1	1	1	1	1
	Yellow	—	1	1	1	1	1	1	1	1	1	1	1	1	0	0	0	0	0	0
	White	—	1	1	1	1	1	1	1	1	1	1	1	1	1	1	1	1	1	1
Gray Scale of Red	Black	GS0	0	0	0	0	0	0	0	0	0	0	0	0	0	0	0	0	0	0
	↑	GS1	1	0	0	0	0	0	0	0	0	0	0	0	0	0	0	0	0	0
	Darker	GS2	0	1	0	0	0	0	0	0	0	0	0	0	0	0	0	0	0	0
	↑	↓				↓				↓				↓					↓	
	↓	↓				↓				↓				↓					↓	
	Brighter	GS61	1	0	1	1	1	1	0	0	0	0	0	0	0	0	0	0	0	0
	↓	GS62	0	1	1	1	1	1	0	0	0	0	0	0	0	0	0	0	0	0
Red	GS63	1	1	1	1	1	1	0	0	0	0	0	0	0	0	0	0	0	0	
Gray Scale of Green	Black	GS0	0	0	0	0	0	0	0	0	0	0	0	0	0	0	0	0	0	0
	↑	GS1	0	0	0	0	0	0	1	0	0	0	0	0	0	0	0	0	0	0
	Darker	GS2	0	0	0	0	0	0	0	1	0	0	0	0	0	0	0	0	0	0
	↑	↓				↓				↓				↓					↓	
	↓	↓				↓				↓				↓					↓	
	Brighter	GS61	0	0	0	0	0	0	1	0	1	1	1	1	0	0	0	0	0	0
	↓	GS62	0	0	0	0	0	0	0	1	1	1	1	1	0	0	0	0	0	0
Green	GS63	0	0	0	0	0	0	1	1	1	1	1	1	0	0	0	0	0	0	
Gray Scale of Blue	Black	GS0	0	0	0	0	0	0	0	0	0	0	0	0	0	0	0	0	0	0
	↑	GS1	0	0	0	0	0	0	0	0	0	0	0	0	1	0	0	0	0	0
	Darker	GS2	0	0	0	0	0	0	0	0	0	0	0	0	0	1	0	0	0	0
	↑	↓				↓				↓				↓					↓	
	↓	↓				↓				↓				↓					↓	
	Brighter	GS61	0	0	0	0	0	0	0	0	0	0	0	0	1	0	1	1	1	1
	↓	GS62	0	0	0	0	0	0	0	0	0	0	0	0	0	1	1	1	1	1
Blue	GS63	0	0	0	0	0	0	0	0	0	0	0	0	1	1	1	1	1	1	

0 : Low level voltage, 1 : High level voltage

Each basic color can be displayed in 64 gray scales from 6 bit data signals. According to the combination of total 18 bit data signals, the 262,144-color display can be achieved on the screen.

9. Optical Characteristics

Ta = 25°C, Vcc=+3.3V

Parameter		Symbol	Condition	Min.	Typ.	Max.	Unit	Remark
Viewing Angle range	Horizontal	θ21	CR > 10	60	70	-	deg.	[Note9-1,9-4]
		θ22		60	70	-	deg.	
	Vertical	θ11		40	50	-	deg.	
		θ12		50	60	-	deg.	
Contrast ratio		CRn	θ=0°	600	—	—		[Note9-2,9-4]
		CRo	Optimum viewing angle	600	1000	—		
Response Time	Rise + Decay	τr+τd	θ=0°	-	30	40	ms	[Note9-3,9-4]
Chromaticity of White		x		0.263	0.313	0.363	-	[Note9-4]
		y		0.279	0.329	0.379	-	
NTSC ratio				-	40	-	%	[Note9-4]
Luminance of white		Y _{L1}		950	1200	-	cd/m ²	I _{LED_F} =70mA [Note9-4]
White Uniformity		δ _w		-	1.20	1.45	-	[Note9-5]

The measurement shall be executed 30 minutes after lighting at rating. Condition : I_{LED_F}=70mA

The optical characteristics shall be measured in a dark room or equivalent.

• Measuring Viewing Angle Range

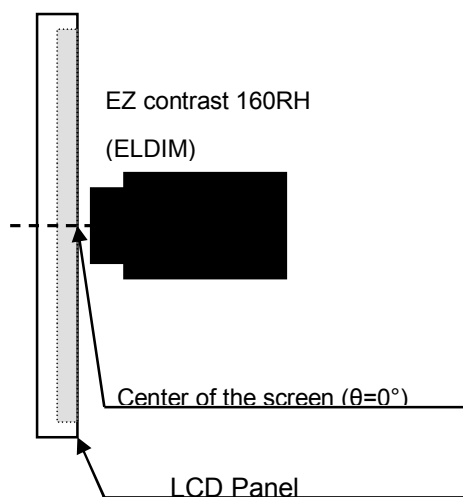

• Other Measurements

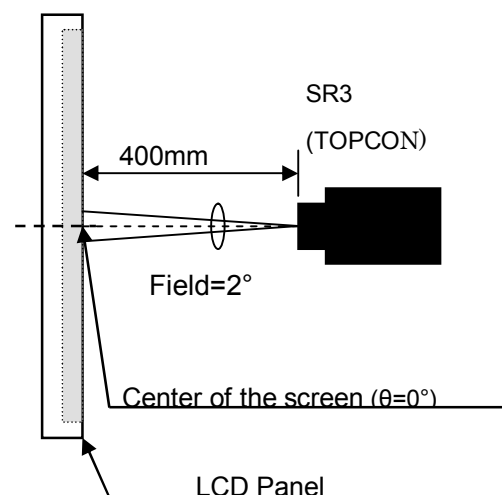

[Note9-1] Definitions of viewing angle range

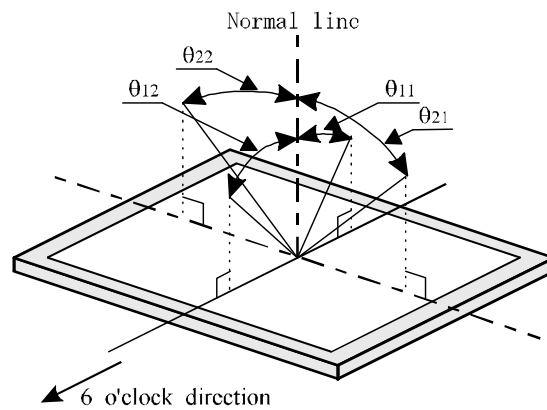

[Note9-2] Definition of contrast ratio

The contrast ratio is defined as the following

$$\text{Contrast ratio (CR)} = \frac{\text{Luminance (brightness) with all pixels white}}{\text{Luminance (brightness) with all pixels black}}$$

[Note9-3] Definition of response time

The response time is defined as the following figure and shall be measured by switching the input signal for "black" and "white"

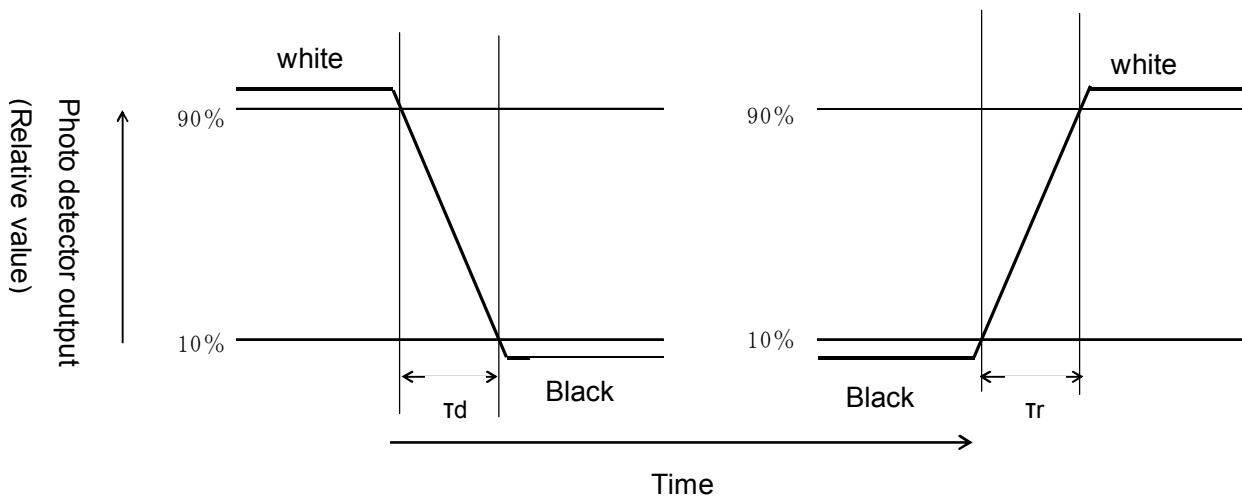

[Note9-4] This shall be measured at center of the screen.

[Note9-5] Definition of Uniformity

$$Uniformity = \frac{\text{Maximum Brightness}}{\text{Minimum Brightness}} \times 100 (\%)$$

The brightness should be measured on the 5-point as shown in the right figure.

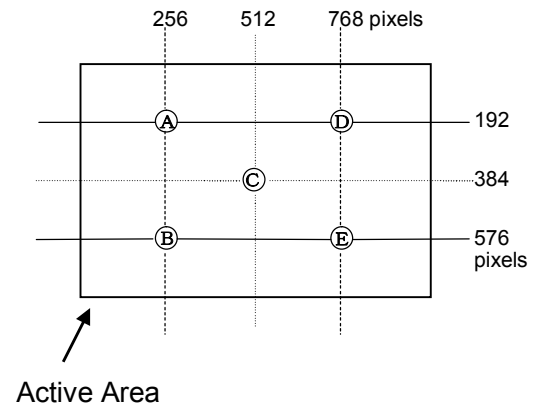

10. Display Quality

The display quality of the color TFT-LCD module shall be in compliance with the Incoming Inspection Standard.

11. Handling Precautions

- a) Be sure to turn off the power supply when inserting or disconnecting the cable.
- b) Be sure to design the cabinet so that the module can be installed without any extra stress such as warp or twist.
- c) Since the front polarizer is easily damaged, pay attention not to scratch it.
Blow away dust on the polarizer with antistatic N₂ blow. It is undesirable to wipe off because a polarizer is sensitive.
It is recommended to peel off softly using the adhesive tape when soil or finger oil is stuck to the polarizer.
When unavoidable, wipe off carefully with a cloth for wiping lenses.
- d) Wipe off water drop immediately. Long contact with water may cause discoloration or spots.
- e) When the panel surface is soiled, wipe it with absorbent cotton or other soft cloth.
- f) Since the panel is made of glass, it may break or crack if dropped or bumped on hard surface.
Handle with care.
- g) Since CMOS LSI is used in this module, take care of static electricity and injure the human earth when handling.
Observe all other precautionary requirements in handling components.
- h) Since there is a circuit board in the module back, stress is not added at the time of a design assembly.
Please make it like. If stress is added, there is a possibility that circuit parts may be damaged.
- i) Protection film is attached to the module surface to prevent it from being scratched .
Peel the film off slowly , just before the use, with strict attention to electrostatic charges.
Blow off 'dust' on the polarizer by using an ionized nitrogen.
- j) Do not expose the LCD module to a direct sunlight, for a long period of time to protect the module from the ultra violet ray.
- k) Connect GND of mounting holes to stabilize against EMI and external noise.
- l) When handling LCD modules and assembling them into cabinets, please avoid that long-terms storage in the environment of oxidization or deoxidization gas and the use of such materials as reagent, solvent, adhesive, resin, etc. which generate these gasses, may cause corrosion and discoloration of the modules.
- m) Liquid crystal contained in the panel may leak if the LCD is broken. Rinse it as soon as possible if it gets inside your eye or mouth by mistake.
- n) Notice : Never dismantle the module , because it will cause failure.
Please don't remove the fixed tape, insulating tape etc that was pasted on the original module.
(Except for protection film of the panel and the crepe tape (yellow tape) of fixing LED FPC temporarily.)
- o) Be careful when using it for long time with fixed pattern display as it may cause afterimage.
(Please use a screen saver etc., in order to avoid an afterimage.)
- p) Adjusting volume has been set optimally before shipment, so do not change any adjusted value.
If adjusted value is changed, the specification may not be satisfied.
- q) Please note that it is likely to damage your eyes when keeping seeing for a long time for a high luminance specification.

12. Packing form

This packing form and the specification are tentative.

This packing form and specification might be changed because they are designing now.

Piling number of cartons	Max 6
Package quantity in one carton	10 pcs
Carton size	474(W)×335(D)×296(H)mm
Total mass of one carton filled with full modules	7500g
Packing form	Fig.1

13. Reliability Test Items

No.	Test item	Conditions
1	High temperature storage test	Ta = 75°C 96h
2	Low temperature storage test	Ta = -35°C 96h
3	High temperature & high humidity operation test	(Ta = 40°C ; 90%RH 120h) (No condensation)
4	High temperature operation test	Ta = 50°C 24h (Temperature of Panel surface is 60°C Max)
5	Low temperature operation test	Ta = -20°C 24h
6	Thermal Shock Test (non- operating)	+75°C(0.5hours) ⇔ -35°C(0.5hours) Tested for 100 cycles
7	Vibration test (non- operating)	Frequency range: 10 to 57Hz Sweep: 0.076mm 57 to 500Hz Acceleration:9.8m/s ² Sweep time: 11minute Test period: 3 hours (1 hours for each direction of X,Y,Z)
8	Shock test (non- operating)	Direction: ±X, ±Y, ±Z, Time: 1 times for each direction. Impact value: 490m/s ² , Action time 11ms
9	Electro static discharge test (non-operating)	Bezel/Panel :IEC61000-4-2 Contact ±10kV Air ±20kV (LCD module is placed on an insulated board and examined.)
10	Electro static discharge test (operating)	Bezel/Panel :IEC61000-4-2 Contact ±8kV Air ±15kV (LCD module is placed on an insulated board and examined.)

[Result Evaluation Criteria]

Under the display quality test conditions with normal operation state, these shall be no change which may affect practical display function.

normal operation state : Temperature:15~35°C, Humidity:45~75%, Atmospheric pressure:86~106kpa

(based on JIS Z 8703)

14. Lot No. marking

14-1. Module Bar code label

Notation: ①SHARP Logo ②Model No. ③Manufacture country ④Serial No. ⑤RoHS mark
 Bar code: ⑥Model No. ⑦Serial No.

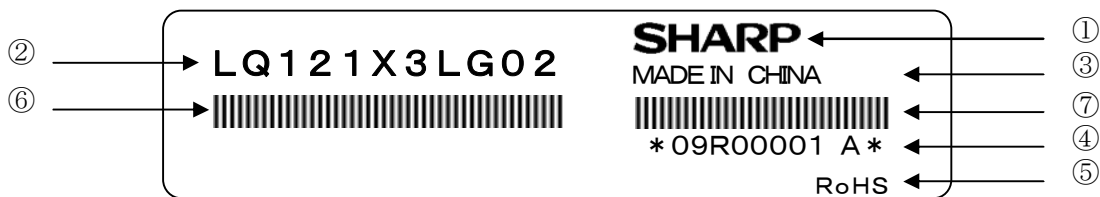

Details of Serial No.

(Example)

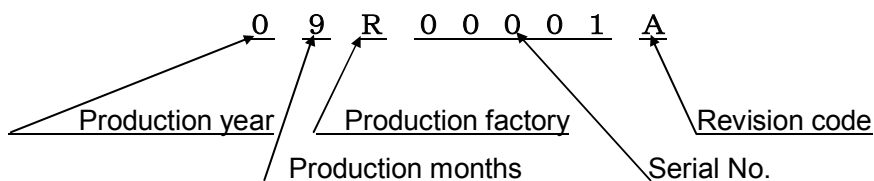

[Note] Production year : 0(2010)、1(2011)、2(2012)、

Production month : 1(Jan)、2(Feb)、、9(Sep)、X(Oct)、Y(Nov)、Z(Dec)

Manufacture country : China
 Production factory : WUXI SHARP ELECTRONIC COMPONENTS CO., LTD.
 (Production factory code at Serial No : 『R』)

14-2. Packing bar code label

Notion / Bar code: ①Model No. ②Date ③Quantity

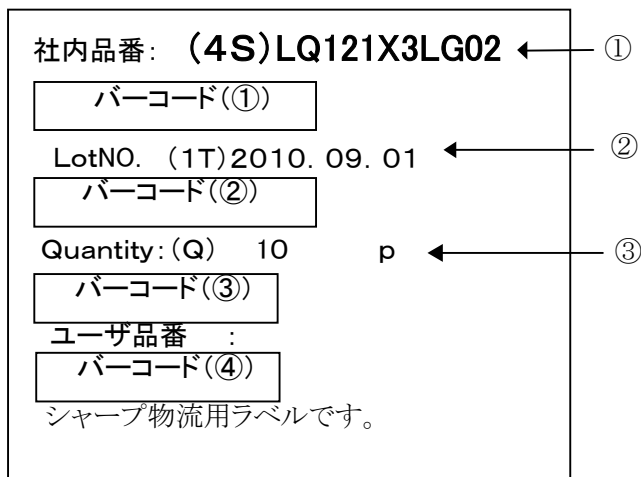

15. RoHS.Regulations

This LCD module is compliant with RoHS Directive.

16. About PFOS

This module doesn't do intentional use about PFOS (perfluorooctanesulfonic acid) and the salt.

17. Storage conditions

<Environmental condition range of storage temperature and humidity>

Temperature 0 to 40 degrees Celsius

Relative humidity 90% and below

Direct sun light

Please keep the product in a dark room or cover the product to protect from direct sun light.

Atmospheric condition

Please refrain from keeping the product with possible corrosive gas or volatile flux.

Prevention of dew

* Please store the product carton either on a wooden pallet or a stand / rak to prevent dew.

Do not place directly on the floor. In addition, to obtain moderate ventilation in between the pallet's top and bottom surfaces, pile the cartons up in a single direction and in order.

* Please place the product cartons away from the strage wall.

* Please maintain the storage area with an appropriate ventilation. It is recommendable to furnish the storage area with equipments such as ventilation systems.

* Please maintain the ambient temperature within the range of natural environmental fluctuation.

Storage period

Within above mentioned conditions, maximum storage period should be one year.

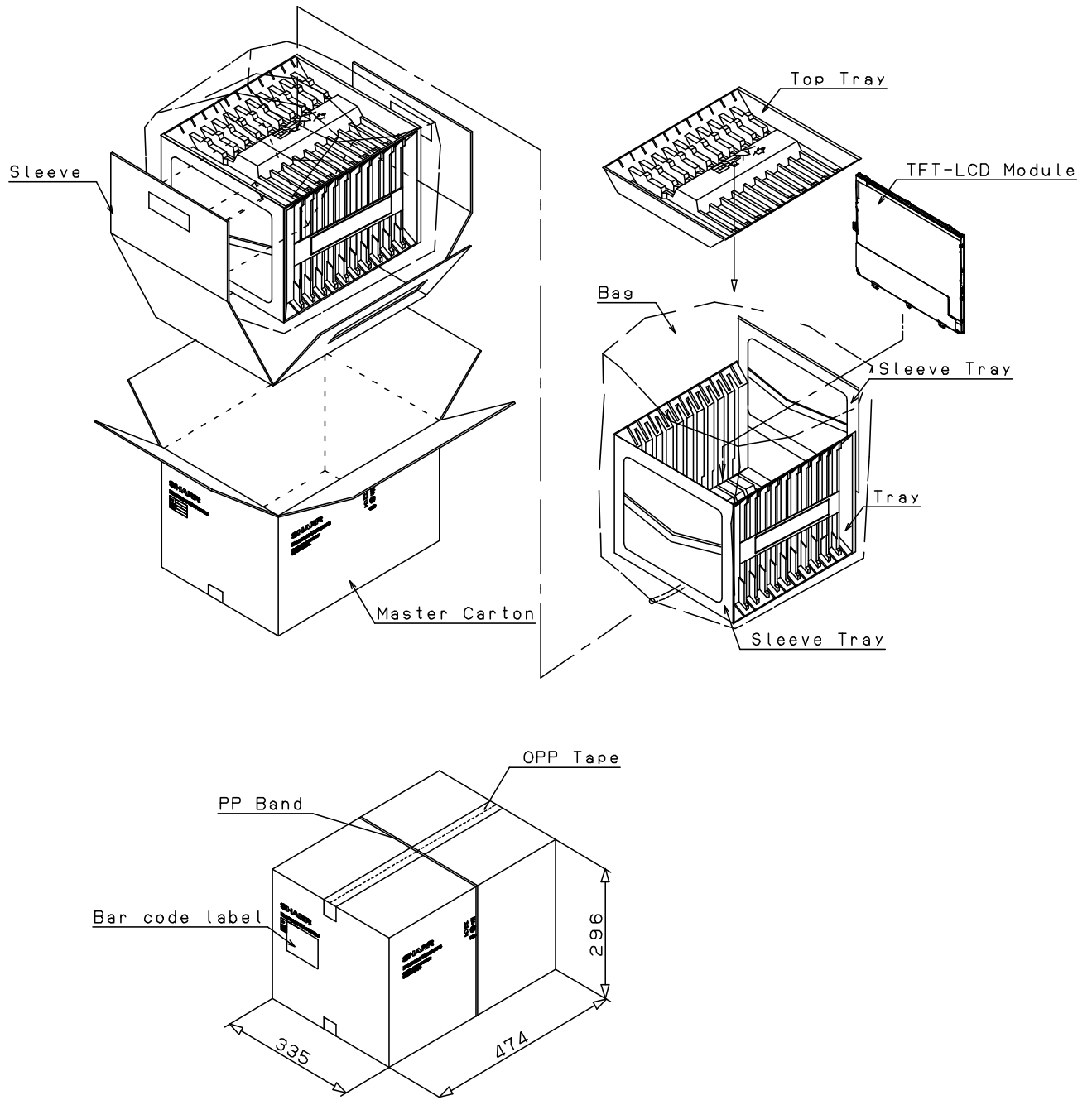
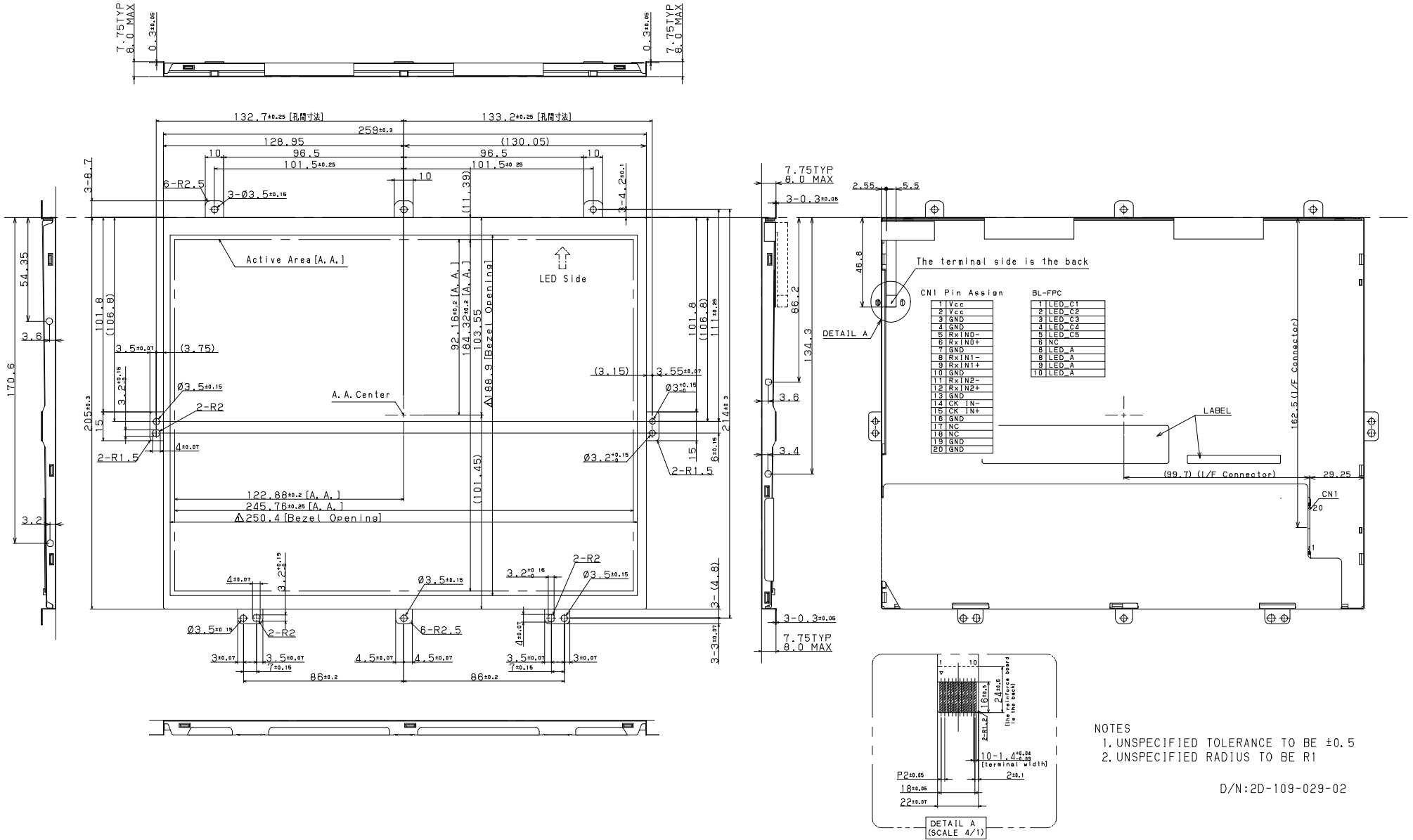

Fig1. LCD module packing carton



1 Fig2. 12.1XGA Outline Dimensions